

# **VAX 4000 Model 200 Technical Information**

Order Number EK-396AB-TM-002

**Digital Equipment Corporation  
Maynard, Massachusetts**

---

**First Printing, December 1990**  
**Revised, June 1991**

The information in this document is subject to change without notice and should not be construed as a commitment by Digital Equipment Corporation.

Digital Equipment Corporation assumes no responsibility for any errors that may appear in this document.

The software, if any, described in this document is furnished under a license and may be used or copied only in accordance with the terms of such license. No responsibility is assumed for the use or reliability of software or equipment that is not supplied by Digital Equipment Corporation or its affiliated companies.

Restricted Rights: Use, duplication or disclosure by the U.S. Government is subject to restrictions as set forth in subparagraph (c)(1)(ii) of the Rights in Technical Data and Computer Software clause at DFARS 252.227-7013.

©Digital Equipment Corporation, 1990, 1991. All rights reserved.

Printed in U.S.A.

The Reader's Comments form at the end of this document requests your critical evaluation to assist in preparing future documentation.

The following are trademarks of Digital Equipment Corporation: CompactTape, CX, DDCMP, DEC, DECconnect, DECdirect, DECnet, DECscan, DECserver, DECUS, DECwindows, DELNI, DEMPR, DESQA, DESTA, DSRVB, DSSI, IVAX, KDA, KLESI, MicroVAX, MSCP, Q-bus, Q22-bus, RA, RQDX, RV20, SA, SDI, ThinWire, TK, TMSCP, TQK, TS05, TU, VAX, VAX 4000, VAXcluster, VAX DOCUMENT, VAXELN, VAXlab, VAXserver, VMS, VT, and the DIGITAL logo.

Amphenol is a trademark of Amphenol Corporation. Bell is a trademark of Bell telephone companies. CHAMP is a registered trademark of AMP Inc. IBM is a trademark of International Business Machines Corporation.

**FCC NOTICE:** The equipment described in this manual generates, uses, and may emit radio frequency energy. The equipment has been type tested and found to comply with the limits for a Class A computing device pursuant to Subpart J of Part 15 of FCC Rules, which are designed to provide reasonable protection against such radio frequency interference when operated in a commercial environment. Operation of this equipment in a residential area may cause interference, in which case the user at his own expense may be required to take measures to correct the interference.

S1686

This document was prepared using VAX DOCUMENT, Version 1.2.

# Contents

---

Preface	vii
---------	-----

---

## Chapter 1 Base System Description

---

1.1	System Overview	1-1
1.2	Firmware Overview	1-3
1.3	Power-Up	1-4
1.4	Console I/O Mode Overview	1-4
1.4.1	Control Characters in Console I/O Mode	1-4
1.4.2	Console I/O Mode Commands	1-6
1.5	Digital Storage Systems Interconnect (DSSI)	1-14
1.6	KA660-AA-BA CPU Specifications	1-15

## Chapter 2 Option Specifications

---

2.1	Options Overview	2-2
2.1.1	Configuration	2-2
2.2	Mass Storage Options	2-3
2.2.1	KDA50 Controller	2-4
2.2.2	KFQSA Storage Adapter	2-5
2.2.3	KLESI Controller	2-6
2.2.4	KZQSA Storage Adapter	2-7
2.2.5	RA60 Disk Drive	2-8
2.2.6	RA70E Disk Drive	2-9
2.2.7	RA81 Disk Drive	2-10
2.2.8	RA82 Disk Drive	2-11
2.2.9	RA90 Disk Drive	2-12
2.2.10	RA92 Disk Drive	2-13
2.2.11	RF31 Integrated Storage Element (ISE)	2-14
2.2.12	RF31F Integrated Storage Element	2-15

2.2.13	RF71 Integrated Storage Element (ISE) . . . . .	2-17
2.2.14	RF72 Integrated Storage Element (ISE) . . . . .	2-18
2.2.15	RRD40 Compact-Disc Subsystem . . . . .	2-20
2.2.16	RRD42 Optical Compact-Disc Subsystem . . . . .	2-21
2.2.17	TF85 Tape Drive . . . . .	2-23
2.2.18	TK50 Tape Drive . . . . .	2-25
2.2.19	TK70 Tape Drive . . . . .	2-27
2.2.20	TLZ04 Tape Drive . . . . .	2-29
2.2.21	TQK70 Controller . . . . .	2-31
2.2.22	TSZ07 Tape Drive . . . . .	2-32
2.2.23	TSV05 Tape Drive . . . . .	2-34
2.2.24	TSV05 Controller . . . . .	2-35
2.2.25	TU81-Plus Tape Drive . . . . .	2-36
2.3	Communications Options . . . . .	2-38
2.3.1	CXA16 Asynchronous Multiplexer (16 lines) . . . . .	2-39
2.3.2	CXB16 Asynchronous Multiplexer (16 lines) . . . . .	2-42
2.3.3	CXY08 Asynchronous Multiplexer (8 Lines) . . . . .	2-45
2.3.4	DESPA Ethernet Controller . . . . .	2-47
2.3.5	DEQRA Token Ring Q-bus Adapter . . . . .	2-48
2.3.6	DFA01 Asynchronous Controller with Integral Modem . . . . .	2-50
2.3.7	DPV11 Synchronous Controller . . . . .	2-52
2.3.8	DSRVB DECserver 200 . . . . .	2-53
2.3.9	DSV11 Synchronous Controller . . . . .	2-55
2.4	Real-Time Options . . . . .	2-56
2.4.1	AAV11-S Digital-to-Analog Converter . . . . .	2-57
2.4.2	ADQ32 Analog-to-Digital Converter . . . . .	2-59
2.4.3	ADV11-S Analog-to-Digital Converter . . . . .	2-61
2.4.4	AXV11 Controller . . . . .	2-63
2.4.5	DIV32 Controller . . . . .	2-65
2.4.6	DRQ3B Parallel Interface . . . . .	2-66
2.4.7	DRV1W Parallel Interface . . . . .	2-67
2.4.8	IBQ01 Controller . . . . .	2-69
2.4.9	IEQ11 Controller . . . . .	2-70
2.4.10	KWV11-S Programmable Real-Time Clock . . . . .	2-71
2.5	Printer Interface . . . . .	2-73
2.5.1	LPV11-SA Printer Interface . . . . .	2-73

2.6	Graphics Adapters . . . . .	2-74
2.6.1	VS30U Graphics Adapter . . . . .	2-74

## Chapter 3 System Expansion

---

3.1	Planning System Expansion . . . . .	3-1
3.2	Completing the VAX 4000 Model 200 Configuration Worksheets . . . . .	3-2

## Index

---

### Examples

---

1-1	SHOW QBUS Display . . . . .	1-9
1-2	SHOW DEVICE Display . . . . .	1-11
1-3	SHOW ETHERNET Display . . . . .	1-11
1-4	SHOW LANGUAGE Display . . . . .	1-12
1-5	SET LANGUAGE Command . . . . .	1-12
1-6	SET BOOT Command . . . . .	1-12

### Figures

---

1-1	VAX 4000 Model 200 Block Diagram . . . . .	1-2
3-1	VAX 4000 Model 200 (BA430 Enclosure) Configuration Worksheet . . . . .	3-3
3-2	VAX 4000 Model 200 (BA215 Enclosure) Configuration Worksheet . . . . .	3-4

### Tables

---

1-1	Console I/O Mode Control Characters . . . . .	1-5
1-2	Console I/O Mode Commands . . . . .	1-7
1-3	Boot Device Names . . . . .	1-13
3-1	Power Requirements . . . . .	3-5

# Preface

---

This manual provides a summary of technical information about the VAX 4000 Model 200 system.

- Chapter 1 describes the base system and lists specifications for the KA660-AA/-BA CPU module and MS650-BA/-BB memory module.
- Chapter 2 describes optional components available for your system and lists their specifications.
- Chapter 3 contains information on expanding your system.

**NOTE:** *You will find a glossary in the VAX 4000 Model 200 Operation manual to help with word definitions and acronyms.*

## Conventions

The following conventions are used in this manual:

---

<b>Convention</b>	<b>Meaning</b>
<code>Return</code>	A key name is shown enclosed to indicate that you press a named key on the keyboard.
<code>Ctrl/x</code>	A sequence such as <code>Ctrl/x</code> indicates that you must hold down the key labeled Ctrl while you press another key.
<b>BOLD</b>	This bold type indicates user input. For example:  >>> <b>BOOT MUA0</b>  The user must enter BOOT MUA0 at the console prompt.
<b>NOTE</b>	Notes provide general information about the current topic.
<b>CAUTION</b>	Information to prevent damage to equipment or software.
<b>WARNING</b>	Information to prevent personal injury.

---

# Chapter 1

## Base System Description

---

This chapter describes the VAX 4000 Model 200 base system, including the following:

- Power-up self tests
- Digital Storage Systems Interconnect (DSSI) architecture
- Specifications for the KA660-AA/BA CPU and MS650-BA/BB memory

### 1.1 System Overview

The VAX 4000 Model 200 base system components are housed in two different enclosures: the BA430 enclosure, which contains a 12-slot Q-bus backplane, and the BA215 enclosure, which contains a 6-slot Q-bus backplane.

Each base system contains the following:

- A KA660-AA/BA (M7626-A/-B) central processing unit (CPU) module
- From one to four MS650-Bx memory modules.

The base system modules are located in the following card slots:

- MS650-Bx memory modules are installed in slots 2 through 5.
- The KA660 CPU module is installed in slot 1.

The base system operates from the KA660 CPU firmware and the controls on the CPU cover panel. The firmware is described in Section 1.2. Base system operation also integrates Digital Storage Systems Interconnect (DSSI) technology, which is discussed in Section 1.5.

Figure 1-1 is a block diagram of the VAX 4000 Model 200 system.

Figure 1-1: VAX 4000 Model 200 Block Diagram

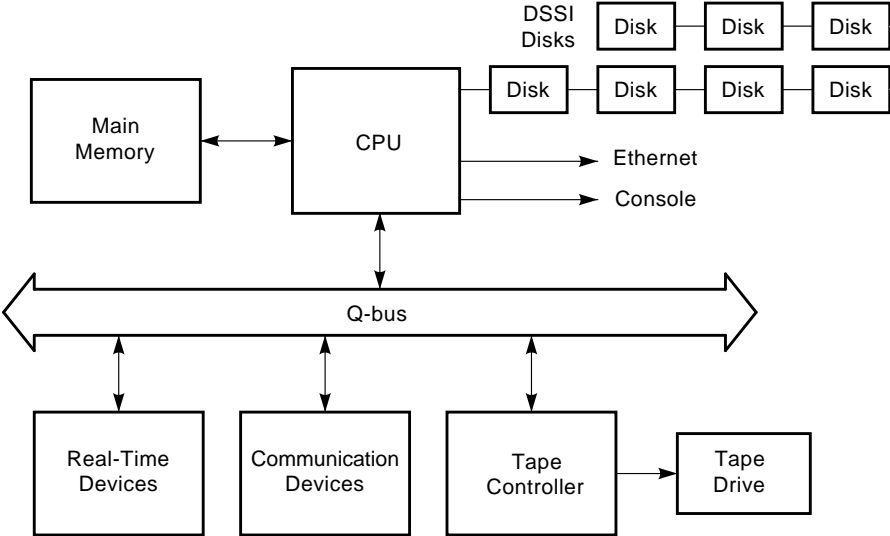

MLO-005710



## 1.2 Firmware Overview

Two electrically programmable read-only memory (EPROM) chips on the KA660 CPU module contain the firmware. This firmware consists of the following three major programs, which perform the system power-up self-tests and diagnostics:

- A console program
- A set of self-tests for the CPU and memory
- A primary bootstrap program (VMB)

The console program receives control whenever the processor halts. In a processor halt, processor control passes to the console program and instruction execution continues. The standard VAX console functionality is emulated whenever you execute a program in ROM.

Control passes to the firmware under any of the following conditions:

- You turn on the system.
- You press the Restart button.
- You assert the Q22-bus BHALT signal by pressing the Halt button.
- You enter a break when the Break Enable/Disable switch is set to enable.
- A HALT instruction is executed.
- A fatal system error occurs.

## 1.3 Power-Up

At power-up, the console program determines the console device type and console language, then runs the self-tests for the CPU and memory. You choose the console language when you perform the set-up operations during your console terminal installation procedure.

You determine the type of power-up mode by setting the Power-Up Mode switch on the CPU cover panel. See your *VAX 4000 Model 200 Operation* manual for the following power-up information:

- Power-up procedures
- Power-Up Mode and Break Enable/Disable switch settings
- Examples of successful power-up sequences
- Boot and autoboot procedures

See the *VAX 4000 Model 200 Troubleshooting and Diagnostics* manual for examples of problems you may encounter during power-up.

## 1.4 Console I/O Mode Overview

If you set the Break Enable/Disable switch on the CPU cover panel to enable, the console program enters Console I/O mode after the power-up self-tests are completed successfully. The console program also enters Console I/O mode in response to any external halt condition.

**CAUTION:** *Do not press the Restart button while the console program is in console mode. Doing so destroys the system state and prevents normal operation.*

Console I/O mode allows you to control the system by entering commands at the console prompt >>>. You may enter these commands in either uppercase or lowercase letters. Enter each command, then press Return.

### 1.4.1 Control Characters in Console I/O Mode

Table 1-1 lists the keypad control characters that have special meaning in Console I/O mode.

**Table 1–1: Console I/O Mode Control Characters**

Character	Action
<code>Return</code> also <CR>	The carriage return ends a command line. No action is taken on a command until after it is terminated by a carriage return. A null line terminated by a carriage return is treated as a valid, null command. No action is taken, and the console prompts for input. Carriage return is echoed as carriage return, line feed (<CR><LF>).
<code>X</code> (rubout)	<p>When you press <code>X</code> (rubout), the console deletes the previously typed character. The resulting display differs, depending on whether the console is a video or a hardcopy terminal.</p> <p><b>For hardcopy terminals</b>, the console echoes a backslash (\) followed by the character being deleted. If you press additional rubouts, the additional deleted characters are echoed. If you type a non-rubout character, the console echoes another backslash, followed by the character typed. The result is to echo the characters deleted, surrounding them with backslashes. For example:</p> <pre>EXAMI;E[X]X]NE&lt;CR&gt;</pre> <p>The console echoes: EXAMI;E\ E\ NE&lt;CR&gt;</p> <p>The console sees the command line: EXAMINE&lt;CR&gt;</p> <p><b>For video terminals</b>, the previous character is erased and the cursor is restored to its previous position.</p> <p>The console does not delete characters past the beginning of a command line. If you press more rubouts than there are characters on the line, the extra rubouts are ignored. A rubout entered on a blank line is ignored.</p>
<code>Ctrl/A</code> or <code>F14</code>	Toggles insertion/overstrike mode for command line editing. By default, the console powers up to overstrike mode.
<code>Ctrl/C</code>	Echoes ^C<CR> and aborts processing of a command. Has no effect as part of a binary load data stream. Clears <code>Ctrl/S</code> and re-enables output stopped by <code>Ctrl/O</code> .
<code>Ctrl/D</code> or <code>←</code>	Moves the cursor one position to the left.
<code>Ctrl/E</code>	Moves the cursor to the end of the line.
<code>Ctrl/F</code> or <code>→</code>	Moves the cursor one position to the right.
<code>Ctrl/B</code> , <code>↑</code> , or <code>↓</code>	Recalls the previous commands.
<code>Ctrl/H</code> , <code>X</code> (rubout), or <code>F12</code>	Deletes the previously typed character. Same function as <code>X</code> (rubout), above.
<code>Ctrl/O</code>	Ignores transmissions to the console until you enter <code>Ctrl/O</code> . Echoes ^O when disabling output, which is not echoed when it re-enables output. Output is re-enabled if the console prints an error message, or if it prompts for a command from the terminal. Output is also enabled by entering Maintenance mode: press <code>Break</code> or enter <code>Ctrl/C</code> .
<code>Ctrl/Q</code>	Resumes output to the console terminal. Not echoed.

**Table 1–1 (Cont.): Console I/O Mode Control Characters**

Character	Action
Ctrl/R	Echoes <CR><LF>, followed by the current command line. Can be used to improve the readability of a command line that has been heavily edited.
Ctrl/S	Stops output to the console terminal until you enter Ctrl/Q. Not echoed.
Ctrl/U	Echoes ^U<CR>. Entered, but otherwise ignored if typed on an empty line.

The console accepts Console I/O mode commands up to 80 characters long. Longer commands produce error messages. The character count does not include rubouts, rubbed-out characters, or the <CR> at the end of the command.

Two or more consecutive spaces and tabs are treated as a single space. Leading and trailing spaces and tabs are ignored. You can place command qualifiers after the command keyword or after any symbol or number in the command.

All numbers (addresses, data, counts) are hexadecimal, but symbolic register names contain decimal register numbers. The hexadecimal digits are 0 through 9 and A through F. You can use uppercase and lowercase letters in hexadecimal numbers (A through F) and commands.

The following symbols are qualifier and argument conventions:

- [ ] = an optional qualifier or argument
- { } = a required qualifier or argument

## 1.4.2 Console I/O Mode Commands

Table 1–2 lists and describes the I/O mode commands. You can display the list of commands by entering **HELP** at the console prompt (>>>).

For a complete explanation of how to use the commands, along with information on qualifiers and arguments, refer to the *KA660 CPU Technical Manual* (EK-KA660-TM).

**Table 1–2: Console I/O Mode Commands**

<b>Command</b>	<b>Action</b>
BOOT	Initializes the processor and transfers execution to the VMB.
CONFIGURE	Invokes an interactive mode that permits you to enter Q22-bus device names, then generates a table of Q22-bus I/O page device CSR addresses and interrupt vectors.
CONTINUE	Causes the processor to begin instruction execution at the address currently contained in the program counter (PC). Does not perform a processor initialization.
DEPOSIT	Deposits data into the address you specify. If you do not specify an address space or data size qualifier, the console uses the last address space and data size used in a DEPOSIT, EXAMINE, MOVE, or SEARCH command.
EXAMINE	Examines the contents of the memory location or register of the address you specify. If you do not specify an address, + is assumed.
FIND	Searches main memory starting at address 0 (zero) for a page-aligned 128-Kbyte segment of good memory, or a restart parameter block (RPB).
HALT	The HALT command has no effect. It is included for compatibility with other VAX consoles.
HELP	Displays the correct syntax for all console commands.
INITIALIZE	Performs a processor initialization.
MOVE	Copies the block of memory starting at the source address to a block beginning at the destination address.
NEXT	Executes the number of macro instructions you specify. If you do not specify a number, 1 (one) is assumed.
REPEAT	Repeatedly displays and executes the command you specify. Press <b>Ctrl/C</b> to stop the command. You can specify any valid console command except the REPEAT command.
SEARCH	Finds all occurrences of a pattern and reports the addresses where the pattern was found. If you include the /NOT qualifier, the command reports all addresses for which the pattern did not match.
SET BFLAG	Sets the default R5 boot flags. The value must be a hexadecimal number of up to eight digits.
SET BOOT	Sets the default boot device. The value must be a valid device name.
SET CONTROLP	Sets Control-P as the console halt condition, instead of a BREAK.
SET HOST	Connects to the DUP or MAINTENANCE driver on the node or device you specify.
SET LANGUAGE	Sets the console language and keyboard type.
SET HALT	Sets the halt action you define. Acceptable values are the following keywords: default, restart, reboot, halt, restart_reboot, or a number in the range 0 to 4 inclusive.

**Table 1–2 (Cont.): Console I/O Mode Commands**

<b>Command</b>	<b>Action</b>
SET RECALL	Sets command recall state to either ENABLED (1) or DISABLED (0).
SHOW BFLAG	Displays the default R5 boot flags.
SHOW BOOT	Displays the default boot device.
SHOW CONTROLP	Shows the current state of Control-P halt recognition, either ENABLED or DISABLED.
SHOW DEVICE	Displays all devices displayed by the SHOW DSSI, SHOW ETHERNET, and SHOW UQSSP commands.
SHOW DSSI	Displays the status of all nodes that can be found on the DSSI bus. For each node on the DSSI bus, the firmware displays the node number, the node name, and the boot name and type of the device, if available. Does not indicate whether the device contains a bootable image.
SHOW ETHERNET	Displays the hardware Ethernet address for all Ethernet adapters that can be found, both on-board and on the Q22-bus.
SHOW LANGUAGE	Displays console language and keyboard type.
SHOW MEMORY	Displays main memory configuration, board by board.
SHOW QBUS	Displays all Q22-bus I/O addresses that respond to an aligned word read, plus vector and device name information. For each address, the console displays the address in the VAX I/O space in hexadecimal, the address as it would appear in the Q22-bus I/O space in octal, and the word that was read in hexadecimal. Also displays the vector that you should set up, and device name or names that could be associated with the CSR.
SHOW RECALL	Displays the current state of command recall, either ENABLED or DISABLED.
SHOW HALT	Displays the halt action. Keywords include: default, restart, reboot, halt, restart_reboot, or a number in the range 0 to 4 inclusive.
SHOW RLV12	Displays all RL01 and RL02 disks that appear on the Q22-bus.
SHOW TRANSLATION	Shows any virtual addresses that map to the specified physical address.
SHOW UQSSP	Displays the status of all disks and tapes that can be found on the Q22-bus that support the UQSSP protocol. For each such disk or tape on the Q22-bus, the firmware displays the controller number, the controller CSR address, and the boot name and type of each device connected to the controller. The command does not indicate whether the device contains a bootable image.
SHOW VERSION	Displays the current firmware version.
START	Starts instruction execution at the address you specify. If you do not give an address, the current program counter is used. If memory mapping is enabled, macro instructions are executed from virtual memory, and the address is treated as a virtual address. Equivalent to a DEPOSIT to PC, followed by a CONTINUE. Does not perform a processor initialization.

**Table 1–2 (Cont.): Console I/O Mode Commands**

<b>Command</b>	<b>Action</b>
TEST	Invokes a diagnostic test program specified by the test number you enter. If you enter a test number of 0 (zero), all tests allowed to be executed from the console terminal are executed. The console accepts an optional list of up to five additional hexadecimal arguments.
UNJAM	Performs an I/O bus reset, by writing a 1 (one) to IPR 55 (decimal).
X	Loads or unloads (that is, writes to memory or reads from memory) the specified number of data bytes through the console serial line (regardless of console type), starting at the specified address. For use by automatic systems communicating with the console.

Examples 1–1 through 1–6 show sample displays for the commonly used commands SHOW and SET.

The SET command sets the parameter to the value you specify. The SHOW command displays the console parameter you specify.

**Example 1–1: SHOW QBUS Display**

```
>>> SHOW QBUS
Scan of QBUS I/O Space
-200000DC (760334) = 0000 (300) TLZ04/TQK70/RRD40/RQC25/KFQSA-DISK
-200000DE (760336) = 0AA0
-200000E0 (760340) = 0000 (304) TLZ04/TQK70/RRD40/RQC25/KFQSA-DISK
-200000E2 (760342) = 0AA0
-200000E4 (760344) = 0000 (310) TLZ04/TQK70/RRD40/RQC25/KFQSA-DISK
-200000E6 (760346) = 0AA0
-20001468 (772150) = 0000 (154) TLZ04/TQK70/RRD40/RQC25/KFQSA-DISK
-2000146A (772152) = 0AA0
-20001F40 (777500) = 0020 (004) IPCR
```

**Example 1–1 (continued on next page)**

### Example 1-1 (Cont.): SHOW QBUS Display

Scan of QBUS Memory Space

>>>

```
-20000120 (760400) = 0080 (300) DHQ11/DHV11/CXA16/CXB16/CXY08
-20000122 (760442) = FO81
-20000124 (760444) = DD18
-20000126 (760446) = 0140
-20000128 (760450) = 0000
-2000012A (760452) = 0000
-2000012C (760454) = 8000
-2000012E (760456) = 0000
-200002C0 (761300) = 0000 (KZQSA)
-200002C2 (761302) = 0000
-200002C4 (761304) = 0000
-200002C6 (761306) = 0000
-200002C8 (761310) = 0007
-200002CA (761312) = 0000
-200002CC (761314) = 0000
-200002CE (761320) = 0000
-200002D2 (761322) = 0000
-200002D4 (761324) = 0000
-200002D6 (761326) = 0000
-200002D8 (761330) = 0000
-200002DA (761332) = 0000
-200002DC (761334) = 0000
-200002DE (761336) = 0000
-200002E0 (761340) = 0000
-200002E2 (761342) = 0000
-200002E4 (761344) = 0000
-200002E6 (761346) = 0400
-200002E8 (761350) = 0000
-200002EA (761352) = 0000
-200002EC (761354) = 0000
-200002EE (761356) = 5049
-200002F0 (761360) = 8420
-200002F2 (761362) = 0000
-200002F4 (761364) = 0100
-200002F6 (761366) = 0080
-200002F8 (761370) = 1E00
-200002FA (761372) = 032A
-200002FC (761374) = 0000
-200002FE (761376) = 014C
-20001940 (774500) = 0000 TKQ50/TQK70/TU81E/RV20/KFQSA--TAPE
-20001942 (774502) = 0BC0
-20001F40 (777500) = 0000
```

Example 1-1 (continued on next page)



### Example 1-1 (Cont.): SHOW QBUS Display

```
Scan of Qbus Memory Space
-30040000 to 3005ffff (01000000 to 01377777)
>>>
```

For each address, the console displays the address in the VAX I/O space in hexadecimal, the address as it would appear in the Q22-bus I/O space in octal, and the word data that was read in hexadecimal.

### Example 1-2: SHOW DEVICE Display

```
>>>SHOW DEVICE
UQSSP Disk Controller 0 (772150)
-DUA0 (RF71)
UQSSP Disk Controller 1 (760334)
-DUB1 (RF71)
UQSSP Disk Controller 2 (760340)
-DUC2 (RF71)
UQSSP Tape Controller 0 (774500)
-MUA0 (TK70)
Ethernet Adapter 0 (774440)
-XQA0 (08-00-2B-09-A3-96)
UQSSP Tape Controller 0 (774500)
-MUA0 (TK70)
Ethernet Adapter
-EZA0 (08-00-2B-06-10-42)
```

For each device, the console displays the controller, the node, and the address on the first line, and the device name and option on the second line.

### Example 1-3: SHOW ETHERNET Display

```
>>> SHOW ETHERNET
Ethernet Adapter
-EZA0 (08-00-2B-0B-29-14)
```

#### **Example 1-4: SHOW LANGUAGE Display**

```
>>> SHOW LANGUAGE
English (United States/Canada)
>>>
```

#### **Example 1-5: SET LANGUAGE Command**

```
>>> SET LANGUAGE 5
>>>
```

#### **Example 1-6: SET BOOT Command**

```
>>> SET BOOT MUA0
>>>
```

In this example, selection 5 is English, chosen from the Language Selection Menu that displays at power-up.

In this example, entering MUA0 sets the tape drive as the default boot device. Table 1-3 lists the supported device names.

**Table 1–3: Boot Device Names**

<b>Device Type</b>	<b>Controller/Adapter</b>	<b>Device Logical Name</b>
RF-series ISE	Embedded DSSI host adapter (part of CPU)	DI <sup>m</sup> n <sup>1</sup>
RF-series ISE	KFQSA storage adapter	DU <sup>c</sup> n <sup>2</sup>
TK-series tape drive	TQK70/TQK50	MU <sup>c</sup> n <sup>3</sup>
TF85 tape drive	Embedded DSSI adapter	MI <sup>m</sup> u <sup>1</sup>
TLZ-series tape drive	KZQSA adapter	MKAn
RRD-series compact disc drive	KZQSA adapter	DKAn
PROM (programmable read-only memory)	MRV11 module	PRAn
Ethernet adapter	On-board (part of CPU)	EZA0
Ethernet adapter	DESPA Ethernet controller	XQAn
RA-series drives	KDA50	DU <sup>c</sup> n <sup>2</sup>

<sup>1</sup>m = DSSI bus adapter (A = first bus (0), B = second bus (1), and so on.)  
n = unit number

When under operating system control, DI<sup>m</sup>n devices are recognized as DIAn devices.

<sup>2</sup>c = MSCP controller designator (A = first, B = second, and so on.)  
n = unit number

<sup>3</sup>c = TMSCP controller designator (A = first, B = second, and so on.)  
n = unit number

## 1.5 Digital Storage Systems Interconnect (DSSI)

The KA660 CPU module contains an embedded DSSI chip on the module which becomes a DSSI bus interface connector that is dedicated to the mass storage devices in the VAX 4000 Model 200 system. (See Figure 1-1 for the VAX 4000 Model 200 block diagram.)

The DSSI bus interface connects to a DSSI Integrated Storage Element (ISE). An ISE is a 5.25-inch disk drive that has special mounting brackets for simplified enclosure installation and upgrading.

Each DSSI bus has the following characteristics:

- A 4-Mbytes-per-second bandwidth
- Up to eight nodes (one interface and up to seven ISEs)
- Eight data lines
- One parity line
- Eight control lines

DSSI architecture improves system performance as follows:

- The DSSI bus handles all mass storage transactions.
- Mass storage devices can act independently, since each device contains its own controller. Several devices can work simultaneously.

The DSSI bus interface supports up to eight nodes. These eight nodes include the DSSI interface and seven ISEs.

An ISE can maintain connections to more than one DSSI interface. In a dual-host configuration in which multiple CPUs can be connected to the DSSI bus interfaces. For example, two VAX 4000 Model 200 systems can have access to each ISE over a shared DSSI bus.

For more information about using VAX 4000 Model 200 systems in a dual-host configuration, and the advantages of such configurations, see the *VAX 4000 Model 200 Dual-Host Systems* manual.

## 1.6 KA660-AA-BA CPU Specifications

The VAX 4000 Model 200 system (in a BA430 enclosure and in a BA215 enclosure) uses the KA660-AA central processing unit. The VAXserver 4000 Model 200 (in a BA430 enclosure and in a BA215 enclosure) uses the KA660-BA central processing unit.

---

### Central Processing Unit

---

Addressing modes	General register: 8
Clock rate	114 MHz
Data path width	64 bits
Number of data types	Hardware: 9 Software emulated: 7
Number of instructions	Hardware: 272 Software emulated: 32
General purpose registers	16 (32-bit wide) Program counter: 4 Index: 9
PDP-11 compatibility mode	Emulated in software
Time bases	Time-of-year clock: 1 (battery backup) Interval timer: 1 (10 milliseconds) Programmable timers: 2
I/O bus interface	One Q22-bus interface with 8192 entry map
Backplane termination	240 $\Omega$

---

### Memory Management and Control

---

Page size	512 bytes
Virtual address space	4 Gbytes
Physical memory space	512 Mbytes
Number of memory modules	4 maximum

---

**Performance**

---

Instruction prefetch buffer size	12 bytes
On-chip cache	
Size	6 Kbytes
Speed	28 nanoseconds
Associativity	Direct mapped
Translation Buffer	
Size	64 entry
Associativity	Fully associative
Q22-bus address translation map cache	
Size	12 entry
Associativity	Fully associative
I/O bus buffer size	
Input	32 bytes
Output	4 bytes
Maximum I/O bandwidth	
Block mode DMA read	2.4 Mbytes/second
Block mode DMA write	3.3 Mbytes/second

---

**Ethernet Port**

---

Supported protocols	Ethernet V2.0
Supported media types	Standard or ThinWire
Data path width	1 bit
Maximum bandwidth	10 Mbits/second
Buffer size	
Transmit buffer	128 bytes/second
Receiver buffer	128 bytes/second

---

**Digital Storage Systems Interconnect (DSSI) Connector**

---

Maximum number of supported devices	7
Data path width	8 bits
Maximum bandwidth	4 Mbytes/second
Maximum queue I/O	800/second
Buffer size	
Transmit buffer	128 bytes/second
Receiver buffer	128 bytes/second

---

**Console Serial Line**

---

Interface standards	EIA RS-423-EIA V.10 X.26 EIA RS-232-C/CCITT V.28 DEC-423
Data format	1 start bit, 8 data bits, 0 parity bits, 1 stop bit
Baud rates	300; 600; 1200; 2400; 4800; 9600; 19,200; 38,400

---

**Configuration Information**

---

Form factor	Quad height
Power requirements	+5 Vdc, 4.8 A; +3.3 Vdc, 0.27 A +12 Vdc (alone), 0.14 A; +12 Vdc (with H3602), 0.55 A; -12 Vdc, 0.04 A
Power consumption	42.6 W
Bus loads	3.5 ac; 1.0 dc

---

**Operating System Support**

---

VMS	Version 5.4-2
VAXELN	Version 3.2

---

**Diagnostic Support**

---

MicroVAX Diagnostic Monitor	Release 134 and later
Self-tests	Yes

---

**Related Documentation**

---

EK-KA660-TM	KA660 CPU Technical Manual
EK-398AA-MM	KA660 CPU System Maintenance

---

## Chapter 2

# Option Specifications

---

This chapter lists specifications for the options currently supported in the VAX 4000 Model 200 system, grouped as follows:

- Mass storage
- Communications
- Real-time
- Printer
- Memory

The specifications appear in alphanumerical order within each of the above groups. All weights are approximate.

Some of the options are already installed in your system. If you want to add other options, your Digital sales representative can advise you.



## 2.1 Options Overview

The option specifications include the following, where applicable:

- Functional information
- Ordering information
- Performance
- Configuration information
- Related documentation

Unless otherwise noted, operating system support and diagnostic support for all options are the same as for the KA660 CPU module.

### 2.1.1 Configuration

Options must be properly configured so that the system recognizes them.

Each option in a system has a device address, commonly referred to as a control and status register (CSR) address, and an interrupt vector that must be set when the option is installed. Options are usually configured by setting switches or jumpers on modules already configured at the factory or Digital service representatives configure the option when they install it in your system.

Self-maintenance customers can find information on setting CSR addresses and interrupt vectors in the *Microsystems Options* volume of the *Entry Systems Service* kit.

## 2.2 Mass Storage Options

The VAX 4000 Model 200 system supports the following mass storage devices:

- Internal to the BA430 and BA215 enclosures:
  - TK-series tape drive
  - TF-series tape drive (BA430 only)
  - TLZ-series tape drive
  - TSZ-series tape drive
  - RF-series integrated storage element (ISE)
- External to the BA430 or BA215 enclosures:
  - RRD-series compact disk subsystem (tabletop)
  - TU81-Plus tape
  - TSV-series tape
  - TLZ-series tape
  - RA-series disks

Four RA-series drives are supported by one KDA50 controller. Seven RF-series ISEs are supported by one DSSI adapter (or in the case of dual-host DSSI busses, two adapters share six ISEs on one bus). You can put only two disk controllers in the Q-bus backplane, two KDA50s, two KFQSAs, or one of each.

Up to four RF-series ISEs can be installed in your system. The CPU communicates with the ISEs through a single Digital Storage Systems Interconnect (DSSI) adapter, which is built into the CPU. Each DSSI bus is capable of supporting seven integrated storage elements.

## 2.2.1 KDA50 Controller

The KDA50 is an intelligent controller that interfaces with up to four SDI-compatible mass storage devices on the Q22-bus.

---

### Functional Information

---

Controller protocol	MSCP
Bad block replacement	Software dependent
Supported drives	RA60, RA70, RA81, RA82, RA90, RA92
Drives per controller	4
Controllers per system	1 maximum for VMS 5.1 2 maximum for VMS V5.2 and later
Drive interconnect	Transformer-coupled radial

---

### Ordering Information

---

KDA50-SF	RA-series disk drive controller, controls up to a maximum of four RA-series devices <sup>1</sup>
KDA50-SG	Second KDA50 controller, for support of up to four RA-series devices, uses three Q-bus slots <sup>1</sup>

---

### Performance

---

Read/Write data transfers	Up to 16-byte block mode DMA
Data buffering	32 Kbytes
Command buffering	20 command and response ring buffers

---

### Configuration Information

---

Form factor	Two quad height
Power requirements	+5 Vdc, 13.5 A (typ); +12 Vdc, 0.03 A (typ)
Power consumption	67.86 W
Bus loads	3.0 ac; 0.5 dc

---

### Related Documentation

---

EK-KDA5Q-UG	KDA50-Q User's Guide
-------------	----------------------

---

<sup>1</sup>Field installed option.

---

## 2.2.2 KFQSA Storage Adapter

The KFQSA is an intelligent storage adapter that allows Q22-bus systems to communicate with storage peripherals based on the Digital Storage Systems Interconnect (DSSI).

---

### Functional Information

---

Controller protocol	SSP: to and from Q22-bus host DSSI: to and from ISEs
Supported drive	RF-series ISEs
Drives per adapter	7
Drive interconnect	Direct
Controllers per system	2 maximum

---

### Ordering Information

---

KFQSA-SG	RF-series ISE adapter, controls up to a maximum of 7 RF-series ISEs
----------	---

---

### Performance

---

Peak transfer rate	4 Mbytes/second
Sustained transfer rate	1.5 Mbytes/second
I/O request throughput	190 I/O requests/second (single-sector reads)
Error detection	DSSI bus parity and check character, all transmissions

---

### Configuration Information

---

Form factor	Quad height
Power requirements	+5 Vdc, 5.5 A (typ)
Power consumption	27.5 W
Bus loads	4.4 ac; 0.5 dc

---

### Related Documentation

---

EK-KFQSA-IN	KFQ Storage Adapter Installation and User Manual
-------------	--

---

### 2.2.3 KLESI Controller

The KLESI-SA is a controller that interfaces with the TU81-Plus tape drive on the Q22-bus.

---

#### Functional Information

---

Controller protocol	TMSCP
Supported drive	TU81-Plus
Drives per adapter	1
Drive interconnect	Direct
Controllers per system	1 maximum

---

#### Ordering Information

---

Included with the TU81-Plus tape drive

---

#### Configuration Information

---

Form factor	Dual
Power requirements	+5 Vdc, 4.0 A (typ); +12 Vdc, 0.0 A (typ)
Power consumption	20.0 W
Bus loads	0.5 ac; 1.0 dc

---

#### Related Documentation

---

EK-LESIB-UG	KLESI-B Module User's and Installation Guide
-------------	--

---

## 2.2.4 KZQSA Storage Adapter

The KZQSA storage adapter controls the TLZ04 and RRD-series devices on the Q22-bus.

---

### Functional Information

---

Adapter protocol	TMSCP
Supported drive	TLZ04; two external cables or two devices
Controllers per system	2

---

### Ordering Information

---

KZQSA-SA	Factory-installed
KZQSA-SF	Field-installed

---

### Performance Information

---

Peak transfer rate	4 Mbytes synchronous
Error detection	Q-bus parity

---

### Configuration Information

---

Form factor	Quad height
Power requirements	+5 Vdc, 5.5 A (typ); +12 Vdc, 0.0 A (typ)
Power consumption	27.5 W
Bus loads	4.4 ac; 1.0 dc

---

### Related Documentation

---

EK-KZQSA-IN	KZQSA Storage Adapter Installation and User Manual
-------------	--

---

## 2.2.5 RA60 Disk Drive

The RA60 disk drive is a high-capacity removable disk drive that provides 205 Mbytes of formatted storage space. The VAX 4000 Model 200 supports these drives in separate storage expansion enclosures only.

---

### Storage Capacity

---

User capacity	205 Mbytes
User capacity (blocks)	400,176

---

### Ordering Information

---

RA60-AF	RA60 disk drive and cables
BC26V-06	Interconnect cable with connector block

---

### Performance

---

Average seek time	41.67 milliseconds
Average rotational latency	8.33 milliseconds
Average access time	50.30 milliseconds
Peak transfer rate	15.84 Mbits/second

---

### Physical Specifications

---

Height	26.52 cm (10.44 in)
Width	48.26 cm (19 in)
Depth	85.09 cm (33.75 in)
Weight	68.95 kg (152 lb)

---

### Configuration Information

---

Form factor	10.5-in high, full rack width
-------------	-------------------------------

---

### Related Documentation

---

EK-ORA60-UG	RA60 Disk Drive User's Guide
-------------	------------------------------

---

## 2.2.6 RA70E Disk Drive

The RA70E disk drive is a high-capacity fixed-disk drive that provides 280 Mbytes of formatted storage space. The VAX 4000 Model 200 supports these drives in separate storage expansion enclosures only.

---

### Storage Capacity

---

User capacity	280 Mbytes
---------------	------------

---

### Ordering Information

---

RA70E-SA	RA70E disk drive, factory installed
RA70E-SF	RA70E disk drive, field installed

---

### Performance

---

Average seek time	19.5 milliseconds
Average rotational latency	7.5 milliseconds
Average access time	27.0 milliseconds
Peak transfer rate	1.4 Mbytes/second

---

### Physical Specifications

---

Height	26.3 cm (10.38 in)
Width	44.5 cm (17.5 in)
Depth	67.3 cm (26.5 in)
Weight	61.2 kg (135 lb)
Form factor	5.25-in high, full rack width

---

### Related Documentation

---

EK-ORA70-PS	RA70 Disk Drive Pocket Reference Card
EK-ORA70-SV	RA70 Disk Drive Service Manual

---



## 2.2.7 RA81 Disk Drive

The RA81 disk drive is a high-capacity fixed-disk drive that provides 456 Mbytes of formatted storage space. The VAX 4000 Model 200 supports these drives in separate storage expansion enclosures only.

---

### Storage Capacity

---

User capacity	456 Mbytes
User capacity (blocks)	891,070

---

### Ordering Information

---

RA81-HA/-HD	RA81 disk drive (120 V/240 V)
RQA81-AA	RA81 disk drive (120 V) with KDA50 controller and BC26V-06 cable
RQA81-AD	RA81 disk drive (240 V) with KDA50 controller and BC26V-6D cable
BC26V-6D	Interconnect cable with connector block

---

### Performance

---

Average seek time	28.00 milliseconds
Average rotational latency	8.32 milliseconds
Average access time	36.30 milliseconds
Peak transfer rate	17.4 Mbits/second

---

### Physical Specifications

---

Height	26.3 cm (10.38 in)
Width	44.5 cm (17.5 in)
Depth	67.3 cm (26.5 in)
Form factor	10.5-in high, full rack width
Weight	61.2 kg (135 lb)

---

### Related Documentation

---

EK-ORA81-SV	RA81 Disk Drive Service Guide
EK-ORA81-UG	RA81 Disk Drive User's Guide

---

## 2.2.8 RA82 Disk Drive

The RA82 disk drive is a high-capacity fixed-disk drive that provides 623 Mbytes of formatted storage space. The VAX 4000 Model 200 supports these drives in separate storage expansion enclosures only.

---

### Storage Capacity

---

User capacity	623 Mbytes
User capacity (blocks)	1,216,660

---

### Ordering Information

---

RA82-AA	RA82 disk drive (120 V) with one BC26V-12 cable
RA82-AD	RA82 disk drive (240 V) with one BC26V-12 cable
BC26V-06	Interconnect cable with connector block

---

### Performance

---

Average seek time	24.00 milliseconds
Average rotational latency	8.33 milliseconds
Average access time	32.33 milliseconds
Peak transfer rate	19.2 Mbits/second

---

### Physical Specifications

---

Height	26.3 cm (10.38 in)
Width	44.5 cm (17.5 in)
Depth	67.3 cm (26.5 in)
Weight	61.2 kg (135 lb)

---

### Configuration Information

---

Form factor	10.5-in high, full rack width
-------------	-------------------------------

---

### Related Documentation

---

EK-ORA82-SV	RA82 Disk Drive Service Guide
EK-ORA82-UG	RA82 Disk Drive User's Guide

---

## 2.2.9 RA90 Disk Drive

The RA90 disk drive is a high-capacity fixed-disk drive that provides 1.2 gigabytes of formatted storage space. The VAX 4000 Model 200 supports these drives in separate storage expansion enclosures only.

---

### Storage Capacity

---

User capacity	1.2 gigabytes
User capacity (blocks)	2,376,153

---

### Ordering Information

---

RA90-NA	RA90 disk drive (120 V)
RA90-ND	RA90 disk drive (240 V)
BC26V-12	Interconnect cable with connector block

---

### Performance

---

Average seek time	18.5 milliseconds
Average access time	8.33 milliseconds
Peak transfer rate	22.2 Mbits/second

---

### Physical Specifications

---

Height	26.6 cm (10.4 in)
Width	23.0 cm (8.7 in)
Depth	68.5 cm (27.0 in)
Weight	13.6 kg (62 lb)

---

### Configuration Information

---

Form factor	10.5-in high, full rack width
Power requirements	+5 Vdc, 1.3 A; +12 Vdc, 2.21 A
Power consumption	18.7 W

---

### Related Documentation

---

EK-ORA90-SV	RA90 Disk Drive Service Guide
EK-ORA90-UG	RA90 Disk Drive User's Guide

---

## 2.2.10 RA92 Disk Drive

The RA92 disk drive provides 1.5 Gbytes of formatted storage space. The VAX 4000 Model 200 supports the RA92 only in separate storage expansion enclosures.

---

### Storage Capacity

---

User capacity	1.5 gigabytes
User capacity (blocks)	2,940,952

---

### Ordering Information

---

RA92-CA/CD	RA92 disk drive (120 V @ 60 Hz; 240 V @ 50 Hz)
BC26J-xx	12-, 25-, 50, or 80-ft. interconnect cable
BC27V-xx	12-, 15-, 25-, 35-, 50-, or 80-ft. interconnect cable

---

### Performance

---

Average seek time	16.5 milliseconds
Single track seek	3.0 milliseconds
Peak transfer rate	22.2 Mbits/second

---

### Physical Specifications

---

Height	26.6 cm (10.42 in)
Width	23.0 cm (8.75 in)
Depth	60.96 cm (24.0 in)
Weight	31.8 kg (70 lb)

---

### Configuration Information

---

Form factor	10.5-in high
Power requirements	+5 Vdc, 1.3 A; +12 Vdc, 2.21 A
Power consumption	18.7 W

---

### Related Documentation

---

EK-ORA92-UG-02	RA90/RA92 User's Guide
----------------	------------------------

---

## 2.2.11 RF31 Integrated Storage Element (ISE)

The RF31 is a DSSI integrated storage element (ISE) that provides 381 Mbytes of formatted storage space. An ISE is a 5.25-inch integrated storage element that is housed in a special mounting bracket for simplified installation and upgrading.

---

### Storage Capacity

---

Data storage capacity	381 Mbytes, formatted
-----------------------	-----------------------

---

### Ordering Information

---

RF31E-AF	381 Mbyte half-height DSSI ISE, field-installed
----------	---

---

### Performance

---

Average seek time	14.7 milliseconds
Average access time	23 milliseconds
Peak transfer rate	4.0 Mbytes/second

---

### Physical Specifications

---

Height	4.40 cm (1.75 in)
Width	14.60 cm (5.75 in)
Depth	20.45 cm (8.25 in)
Weight	1.81 kg (4.0 lb)

---

### Configuration Information

---

Form factor	Standard 5.25-in footprint
Power requirements	+5 Vdc, 1.3 A; +12 Vdc, 2.21 A
Power consumption	18.7 W

---

### Related Documentation

---

EK-RF72D-IM	RF31/RF72 Installation Manual for BA200 Enclosures
EK-RF72D-UG	RF31/RF72 User Guide

---

## 2.2.12 RF31F Integrated Storage Element

The RF31F is a DSSI integrated storage element (ISE) that provides 200 Mbytes of formatted storage space. The RF31F features a code modification to the UVE ROM that makes the RF31F a half-stroke drive.

---

### Storage Capacity

---

Data storage capacity	200 Mbytes, formatted
-----------------------	-----------------------

---

### Ordering Information

---

RF31F-EA	200-Mbyte half-height ISE, no mounting hardware
RF31F-AF	200-Mbyte half-height ISE, field-installed

---

### Performance

---

Average seek time	12.3 milliseconds
Average access time	20.6 milliseconds
Peak transfer rate	4.0 Mbytes/second
Transfer rate from the media	2.0 Mbytes/second

---

### Physical Specifications

---

Height	4.40 cm (1.75 in)
Width	14.60 cm (5.75 in)
Depth	20.45 cm (8.25 in)
Weight	1.81 kg (4.0 lb)

---

**Configuration Information**

---

Form factor	Standard 5.25-in footprint
Data surfaces	8
Bits per inch	30,064
Tracks per inch	1,875
Power requirements	+5 Vdc, 1.3 A; +12 Vdc, 2.21 A (seeking)
Power consumption	18.7 W

---

**Related Documentation**

---

EK-RF72D-UG-004	RF31/RF72 User Guide
EK-RF72D-IM-002	RF31/RF72 Installation Manual

---

### 2.2.13 RF71 Integrated Storage Element (ISE)

The RF71 is a DSSI integrated storage element (ISE) that provides 400 Mbytes of formatted storage space. An ISE is a 5.25-inch integrated storage element that is housed in a special mounting bracket for simplified installation and upgrading.

---

#### Storage Capacity

---

User capacity	400 Mbytes
User capacity (blocks)	781,440

---

#### Ordering Information

---

RF71E-AA	400 Mbyte DSSI ISE
----------	--------------------

---

#### Performance

---

Average random seek time	19.20 milliseconds
Average rotational latency	8.33 milliseconds
Average access time	34.2 milliseconds
Peak transfer rate	1.5 Mbits/second

---

#### Physical Specifications

---

Height	7.75 cm (3.05 in)
Width	14.60 cm (5.75 in)
Depth	20.75 cm (8.17 in)
Weight	4.09 kg (9.0 lb)

---

#### Configuration Information

---

Form factor	Standard 10.5-in footprint
Power requirements	+5 Vdc, 1.25 A; +12 Vdc, 1.64 A
Power consumption	25.93 W

---

#### Related Documentation

---

EK-RF71D-IM	RF71 Disk Drive Installation Manual
EK-RF71D-UG	RF71 Disk Drive User's Guide

---



## 2.2.14 RF72 Integrated Storage Element (ISE)

The RF72 is a DSSI integrated storage element (ISE) that provides 1.0 Gbytes of formatted storage space. RF-series ISEs are used in DSSI busses (Digital Storage Systems Interconnect). An ISE is a 5.25-inch integrated storage element that is housed in a special mounting bracket for simplified installation and upgrading.

---

### Storage Capacity

---

User capacity	1.0 Gbytes
---------------	------------

---

### Ordering Information

---

RF72E-AA	1.0 Gbyte ISE
----------	---------------

---

### Performance

---

Average seek time	13.3 milliseconds
Average raw seek time, high speed	10.3 milliseconds
Average rotational latency	18.6 milliseconds
Peak transfer rate	2.0 Mbytes/second

---

### Physical Specifications

---

Height	7.75 cm (3.05 in)
Width	14.60 cm (5.75 in)
Depth	20.75 cm (8.17 in)
Weight	4.09 kg (9.0 lb)

---

### Configuration Information

---

Form factor	Standard 5.25-in high, full rack width
Power requirements	+5 Vdc, 1.25 A; +12 Vdc, 3.12 A
Power consumption, spin-up	57.1 W
Power consumption, seeking	27.7 W

---

**Related Documentation**

---

EK-RF72D-IM	RF31/RF72 Installation Manual for BA200 Enclosures
EK-RF72D-UG	RF31/RF72 User Guide

---

## 2.2.15 RRD40 Compact-Disc Subsystem

The RRD40 is a CD reader that retrieves data in fixed-length blocks from removable compact-disc media.

---

### Functional Information

---

Modes	Idle mode Operation mode: search, normal play
Orientation	Horizontal

---

### Ordering Information

---

RRD40-SF	Field-installed tabletop CDROM drive
----------	--------------------------------------

---

### Performance

---

Motor stop time	30% of nominal speed within 30 seconds maximum, 5 seconds typical
Motor start time	90% of nominal speed within 20 seconds maximum, less than 11 seconds typical
Formatted capacity	525 Mbytes with maximum of 600 Mbytes
Average transfer rate	153.6 Kbytes/s, mode 1; 176.4 Kbytes/s, mode 2
Average latency	60 $\mu$ s max inner track; 155 $\mu$ s outer track
Initialization time	15 seconds maximum to sector zero

---

### Physical Specifications

---

Height	27.6 cm (11.02 in)
Width	8.18 cm (3.27 in)
Depth	22.7 cm (9.06 in)
Weight	5.0 kg (11.0 lb)

---

### Configuration Information

---

Power consumption	19.2 W max; Play mode: 18 W max
-------------------	---------------------------------

---

### Related Documentation

---

EK-RRD40-OM	RRD40 Disk Drive Owner's Manual
EK-RRD40-SU	RRD40 MicroVAX Monitor User's Guide Updates

---

## 2.2.16 RRD42 Optical Compact-Disc Subsystem

The RRD42 is a 600-Mbyte optical CD reader that retrieves data in fixed-length blocks from removable compact-disc media.

---

### Functional Information

---

Interface	SCSI-2, single-ended, asynchronous To Q-bus systems through KZQSA storage adapter
-----------	--

---

### Ordering Information

---

RRD42-AA	Embedded disc drive with controller
RRD42-DA	Tabletop model, with power supply

---

### Performance

---

Seek time, average	400 millisecond, (typical)
Seek time, max full stroke	800 millisecond, (typical)
Rotational speed, innermost track	530 rpm
Rotational speed, outermost track	200 rpm
Start time	2.0 second (max)
Stop time	2.0 second (max)
Transfer rate, sustained	150 Kbytes/second
Transfer rate, burst	1.50 Mbytes/second (max)

---

### Physical Specifications

---

Height	4.15 cm (1.62 in)
Width	14.60 cm (5.75 in)
Depth	20.80 cm (8.0 in)
Weight	
-AA	1.30 kg (2.8 lb)
-DA	2.9 kg (6.30 lb)



## 2.2.17 TF85 Tape Drive

The TF85 is a cartridge tape subsystem that can store up to 2.6 Gbytes. The TF85 is a streaming tape drive with a built-in DSSI (Digital Storage Systems Interconnect) controller, and can be used as a part of a DSSI VAXcluster.

---

### Functional Information

---

Recording media	Magnetic, metal-particle tape
Tape dimensions	1.27 cm (0.5 in) wide, 366 m (1100 ft) long
Mode of operation	Streaming
Recording method	Serpentine
Recording density	42,500 bits/in
Number of tracks	48
Storage capacity	2.6 Gbytes, formatted
Transfer rate	800 Kbytes/second, formatted

---

### Ordering Information

---

TF85-AA	2.6 GB cartridge tape subsystem for DSSI-based systems; includes tape drive, DSSI controller, tape cartridge, and head cleaning cartridge
TF85E-JA	Same as -AA but factory-installed
TF85-TA	Same as -AA but tabletop version, 120 V
TF85-TB	Same as -AA but tabletop, 220 V

---

### Performance

---

Tape start time	300 milliseconds maximum
Tape stop time	300 milliseconds maximum
Tape speed	390 cm/second (100 in/second)
Streaming data rate	800 Kbytes/second
Access time (from insertion of tape)	
TF85 mode	3 min max
TK70/50 mode	60 min max
Recording technique	Two-track parallel, serpentine
Burst rate on DSSI bus	3.8 Mbytes/second

---

**Physical Specifications**

---

Height	8.25 cm (3.25 in)
Width	14.60 cm (5.70 in)
Depth	21.44 cm (8.44 in)
Weight	15.4 kg (7.0 lb)

---

**Configuration Information**

---

Form factor	Half-rack, near 5.25-in footprint
Power requirements	+5 Vdc, 1.8 A (typ); +12 Vdc, 1.0 A (typ)
Power consumption	36.3 W
Bus loads	0.0 ac; 0.0 dc

---

**Related Documentation**

---

EK-OTF85-OM	TF85 Cartridge Tape Subsystem Owner's Manual
EK-OTK85-RC	TL85 Cartridge Tape Drive Reference Card

---

## 2.2.18 TK50 Tape Drive

The TK50 is a streaming-tape drive subsystem that can store up to 95 Mbytes on a tape cartridge for backup data storage.

---

### Functional Information

---

Recording media	Magnetic tape
Tape dimensions	1.27 cm (0.5 in) wide, 182.9 m (600 ft) long
Mode of operation	Streaming
Recording method	Serpentine
Recording density	6667 bits/in
Number of tracks	22
Storage capacity	94.5 Mbytes formatted

---

### Ordering Information

---

TK50E-AF	95 Mbyte cartridge tape drive
TQK50-SF	Controller for TK50E-AF

---

### Performance

---

Tape start time	300 milliseconds maximum
Tape speed	2925 cm (75 in)/second
Streaming data rate	62 Kbytes/second
Access time (from insertion of tape)	60 minutes maximum



---

**Physical Specifications**

---

Height	8.25 cm (3.25 in)
Width	14.60 cm (5.70 in)
Depth	21.44 cm (8.44 in)
Weight	2.27 kg (5.0 lb)

---

**Configuration Information**

---

Form factor	Standard 5.25-in footprint
Power requirements	+5 Vdc, 1.5 A; +12 Vdc, 2.4 A
Power consumption	36.3 W
Bus loads	0.0 ac; 0.0 dc

---

**Related Documentation**

---

EK-LEP05-OM	TK50 Tape Drive Owner's Manual
EK-OTK50-UG	TK50 Tape Drive Subsystem Users Guide

---

## 2.2.19 TK70 Tape Drive

The TK70 is a streaming-tape-drive subsystem that can store up to 296 Mbytes on a tape cartridge for backup data storage. The TK70 can read data from cartridges recorded on a TK50 drive, but cannot write data to cartridges recorded on a TK50 drive.

---

### Functional Information

---

Recording media	Magnetic tape
Tape dimensions	1.27 cm (0.5 in) wide, 182.9 m (600 ft) long
Mode of operation	Streaming
Recording method	Serpentine
Recording density	10,000 bits/in
Number of tracks	48
Storage capacity	296 Mbytes formatted

---

### Ordering Information

---

TK70E-AF	296 Mbyte cartridge tape drive
TQK70-SF	Controller for TK70E-AF

---

### Performance

---

Tape start time	325 milliseconds maximum
Tape stop time	200 milliseconds maximum
Tape speed	390 cm/second (100 in/second)
Streaming data rate	125 Kbytes/second
Access time (from insertion of tape)	60 minutes maximum

---

### Physical Specifications

---

Height	8.25 cm (3.25 in)
Width	14.60 cm (5.70 in)
Depth	21.44 cm (8.44 in)
Weight	2.27 kg (5.0 lb)

---

**Configuration Information**

---

Form factor	Standard 5.25-in footprint
Power requirements	+5 Vdc, 1.35 A; +12 Vdc, 2.4 A
Power consumption	35.6 W
Bus loads	0.0 ac; 0.0 dc

---

**Related Documentation**

---

EK-OTK70-OM	TK70 Tape Drive Subsystem Owner's Manual
EK-OTK70-TM	TK70 Tape Drive Subsystem Technical Manual
EK-OTK70-SM	TK70 Tape Drive Subsystem Service Manual

---

## 2.2.20 TLZ04 Tape Drive

The TLZ04 is a 1.2 Gbyte cassette (DAT) SCSI tape drive, either tabletop or embedded in the VAX 4000 Model 200 system.

---

### Functional Information

---

Recording media	Magnetic tape
Mode of operation	Streaming and start/stop
Storage capacity	1.2 Gbytes formatted
Drive interface	RDAT compatible

---

### Ordering Information

---

TLZ04-JA	Embedded (factory installed)BA400-series
TLZ04-JF	Embedded (field installed)BA400-series
TLZ04-DA	Tabletop
TLZ04-GA	Tabletop including BC06P cable

---

### Performance

---

Passes per cassette tape	300
Media	TLZ04-CA cassette tape
Bit density	114 Mbits/square inch
Transfer rate (sustained)	183 Kbytes/second
Recording format	Digital data storage (DDS)
Read/write speed	0.87 cm/second
Peak transfer rate, raw	180 Kbytes/second
Peak transfer rate,user data	170 Kbytes/second
Average file access time	20 seconds
Rewinding time	40 seconds

---

**Physical Specifications**

---

Height	10.0 cm (3.8 in), tabletop 8.2 cm (3.35 in), embedded
Width	32.5 cm (12.7 in), tabletop 14.60 cm (5.70 in), embedded
Depth	28.5 cm (11.2 in), tabletop 21.44 cm (8.44 in), embedded
Weight	7.72 kg (17 lb), tabletop 2.20 kg (7.72 lb), embedded

---

**Data Organization**

---

Recording technology	Helical scan
Recording method	Digital Data Storage (DDS)
Recording density	61,000 bits/inch
Record size	Variable
Maximum capacity	1.2 Gbytes, formatted
Recording medium	60 m x 4 mm

---

**Maintenance**

---

Recommended cleaning cartridge	Every 25 hours
--------------------------------	----------------

---

**Configuration Information**

---

Form factor	5.25-in DAT drive
Power Requirements	90 to 132 V, 1.6 A; 198.0 to 264 V, 1.0 A
Power consumption (embedded)	15.0 W
Power consumption (tabletop)	50.0 W

---

**Related Documentation**

---

EK-TLZ04-MM	TLZ04 Tape Drive Subsystem Service Manual
EK-BA400-IN	Tape Drive Subsystem Service Manual
EK-TLZ04-OM	TLZ04 Tape Drive Owner's Manual

---

## 2.2.21 TQK70 Controller

The TQK70 controller module provides the interface between the TK70 tape drive and the Q22-bus.

---

### Functional Information

---

Controller protocol	TMSCP
Supported drive	TK70
Drives per controller	1
Drive interconnect	Direct
Controllers per system	1 maximum

---

### Ordering Information

---

TQK70-SA	Controller for TK70E-AF
TQK70-SF	Controller for TK70E-AF, field-installed

---

### Performance

---

Data throughput rate	125 Kbytes/second
Read/Write data transfers	Up to 16-word burst mode DMA, truncated to 8-word burst mode if another device is requesting the bus
Buffer size	64 Kbytes

---

### Configuration Information

---

Form factor	Dual height
Power requirements	+5 Vdc, 3.5 A; +12 Vdc, 0.0 A
Power consumption	17.5 W
Bus loads	4.3 ac; 0.5 dc

---

### Related Documentation

---

EK-OTK70-OM	TK70 Tape Drive Subsystem Owner's Manual
-------------	--

---

## 2.2.22 TSZ07 Tape Drive

The TSZ07 is a high-capacity, streaming, 9-track, reel-to-reel, half-inch magnetic tape drive with dual recording densities. The TSZ07 is available in tabletop, cabinet, or rackmount models, and cannot be mounted inside the VAX 4000 Model 200 system.

---

### Functional Information

---

Recording densities	1600 bits/inch or 6250 bits/inch
Mode of operation	Streaming and start/stop
Storage capacity	40 Mbytes with 8-Kbyte blocks, formatted
Number of tracks	9 on 0.5-inch magnetic tape
Drive interface	RDAT compatible

---

### Ordering Information

---

TSZ07-AA	Rackmount, specify country kit
TSZ07-BA	Cabinet, 120 V
TSZ07-BB	Cabinet, 240 V
TSZ07-CA	Tabletop, specify country kit

---

### Performance

---

Transfer rate	4 Mbytes/s
Load/unload time	55 s
Recording speed	100 in/s
Rewinding speed	150 s (with 2400 reel)

---

**Physical Specifications**

---

Tabletop	
Height	26.78 cm (10.50 in)
Width	50.36 cm (19.75 in)
Depth	68.85 cm (27.00 in)
Weight	36.8 kg (81 lb)
Rackmount	
Height	22.32 cm (8.75 in)
Width	43.35 cm (17.0 in)
Depth	64.03 cm (25.5 in)
Weight	31.8 kg (70 lb)
Cabinet	
Height	101.0 cm (40.0 in)
Width	56.10 cm (22.0 in)
Depth	76.50 cm (30.0 in)
Weight	180.1 kg (238 lb)

---

**Maintenance**

---

Recommended cleaning cartridge	Every 25 hours
--------------------------------	----------------

---

**Configuration Information**

---

Form factor	5.25-in DAT drive
Power consumption	385 W, cabinet
	355 W, tabletop
	355 W, rackmount

---

**Related Documentation**

---

EK-TSZ07-IN-002	TSZ07 Installation/Owner's Manual
EK-TSZ07-TM-002	TSZ07 Technical Manual

---



### 2.2.23 TSV05 Tape Drive

The TSV05 is a magnetic streaming-tape-drive that provides 40.5 Mbytes of backup data storage. The TSV05 reads or writes up to 160 Kbytes per second in standard ANSI format.

---

#### Functional Information

---

Recording media	Magnetic tape, 26.7 cm (10.5 in) reel
Tape dimensions	1.27 cm (0.5 in) wide, 731 m (2400 ft) long
Mode of operation	Streaming
Recording method	Phase encoded (PE)
Recording density	1600 bits/in
Number of tracks	9
Storage capacity	40 Mbytes formatted

---

#### Ordering Information

---

TSV05-SB	TSV05 tape drive subsystem
----------	----------------------------

---

#### Performance

---

Handling	Bidirectional reel-to-reel with compliance arm
Tape velocity	64 or 254 cm/second (25 or 100 in/second)
Maximum data transfer rate	40 or 160 Kbytes/second
Rewind time (731 m (2400 ft))	2.8 minutes

---

#### Physical Specifications

---

Height	23.0 cm (8.75 in)
Width	43 cm (17 in)
Depth	62 cm (24.5 in)
Weight	36 kg (80 lb)
Form factor	10.5-in high, full rack width

---

#### Related Documentation

---

EK-TSV05-UG	TSV05 Tape Transport System User's Guide
EK-TSV05-TM	TSV05 Tape Transport Subsys Tech Manual

---

## 2.2.24 TSV05 Controller

The TSV05 tape drive controller interfaces the TSV05 tape drive to the Q22-bus.

---

### Functional Information

---

Controller protocol	Controller unique
Supported drive	TSV05
Drives per controller	1
Drive interconnect	Direct

---

### Ordering Information

---

TSV05-SB	TSV05 tape drive subsystem
----------	----------------------------

---

### Performance

---

Buffer size	3.5 Kbytes
-------------	------------

---

### Configuration Information

---

Form factor	Quad height
Power requirements	+5 Vdc, 6.5 A (typ); +12 Vdc, 0.0 A (typ)
Power consumption	32.5 W
Bus loads	2.4 ac; 1.0 dc

---

### Related Documentation

---

EK-TSV05-UG	TSV05 Tape Transport System User's Guide
-------------	--

---

## 2.2.25 TU81-Plus Tape Drive

The TU81-Plus is a reel-to-reel tape drive mounted in a 101.6-cm (40-in) cabinet. The drive supports two industry-standard recording methods: group coded recording (GCR) and phase encoded (PE).

---

### Storage Capacity

---

PE unformatted	45.3 Mbytes
PE formatted	40.0 Mbytes
GCR unformatted	177 Mbytes
GCR formatted	140 Mbytes

---

### Functional Specifications

---

Recording media	Magnetic tape
Tape dimensions	1.27 cm (0.5 in) wide, 731 m (2400 ft) long
Mode of operation	Streaming
Recording methods	Group code recording (GCR) Phase encoded (PE)
Recording density	6250 bits/in (GCR) 1600 bits/in (PE)
Number of tracks	9

---

### Ordering Information

---

TU81E-DA	TU81-Plus tape drive, KLESI controller for 120 V
TU81E-DB	TU81-Plus tape drive, KLESI controller for 240 V

---

### Performance

---

Handling	Bidirectional reel-to-reel
Tape velocity	
High speed	190.5 cm/second (75 in/second)
Low speed	63.5 cm/second (25 in/second)
Channel data transfer rate	
PE high speed	120 Kbytes/second
PE low speed	40 Kbytes/second
GCR high speed	469 Kbytes/second
GCR low speed	156 Kbytes/second
Rewind time (731.5 m (2400 ft) tape on 26.7 cm (10.5 in) reel)	2.75 minutes maximum

---

**Physical Specifications**

---

Height	105.8 cm (41.7 in)
Width	54.6 cm (21.5 in)
Depth	76.2 cm (30.0 in)
Weight	139 kg (295 lb)

---

**Related Documentation**

---

EK-TU81E-UG	TU81-Plus Tape Subsystem User's Guide
-------------	---------------------------------------

---

## 2.3 Communications Options

The VAX 4000 Model 200 system supports the following communications options:

- CXA16 asynchronous multiplexer (16 lines)
- CXB16 asynchronous multiplexer (16 lines)
- CXY08 asynchronous multiplexer (8 lines)
- DESQA Ethernet controller
- DFA01 asynchronous controller with integral modem
- DPV11 synchronous interface
- DSRVB DECserver 200
- DSV11 synchronous controller

### Asynchronous Serial Controllers

Asynchronous serial controllers provide low-speed connections between peripheral devices and the system. Asynchronous communications between the system and the peripheral depends on recognition of a pattern of start and stop bits, not on a time interval.

### Synchronous Serial Controllers

Synchronous serial controllers provide high-speed connections between systems. Communication between synchronous devices depends on time intervals that are synchronized before transmission of data begins.

### Ethernet Controllers

Ethernet controllers connect your system to an Ethernet network. With a network connection and appropriate DECnet software, you can use all network services.

### 2.3.1 CXA16 Asynchronous Multiplexer (16 lines)

The CXA16 is an intelligent, preprogrammed serial controller that can operate in either DHV11 or DHU11 mode, depending on the setting of an on-board switch. The module contains 16 multiplexed lines.

---

#### Functional Information

---

Supported line interfaces	EIA RS-423-A/CCITT V.10 EIA RS-232-D/CCITT V.28 DEC-423
Split-speed operation	All lines
Flow control (XON/XOFF)	All lines
Supported data formats	16 programmable formats (each with 1 start bit) <ul style="list-style-type: none"><li>• 5, 6, 7, or 8 data bits, 0 or 1 parity bit, and 1 stop bit</li><li>• 5 data bits, 0 or 1 parity bit, and 1.5 stop bits</li><li>• 6, 7, or 8 data bits, 0 or 1 parity bit, and 2 stop bits</li></ul>
Modem control	Parity, if enabled, can be either odd or even. None

---

---

#### Ordering Information

---

CXA16-AF	CXA16 field-installed kit. Includes two 7.6-m (25-ft) BC16D-25 cables, two H3104 cable concentrators, and other accessories required to install the option. <ul style="list-style-type: none"><li>• BC16D-25 cable—data only, 36-conductor, terminated with 36-pin Amphenol male connectors</li><li>• H3104 cable concentrator—concentrates eight BC16E cables into one BC16D cable; eight modified modular jacks and one 36-pin Amphenol female connector</li></ul>
----------	--

---

## Ordering Information

---

BC16E-series cable	Office cable—data only, six-conductor, terminated with modified modular plugs <ul style="list-style-type: none"><li>• BC16E-10: 3 m (10 ft)</li><li>• BC16E-25: 7.6 m (25 ft)</li><li>• BC16E-50: 15.2 m (50 ft)</li></ul>
H8572	Cable extender with modified modular jacks.
H8571-A	25-pin passive adapter <sup>1</sup>
H8571-B	9-pin passive adapter <sup>1</sup>
H3105	Active adapter. Converts EIA RS-232-D signals to DEC-423 signals.

---

## Performance

---

Transmit data transfers	Single-character transfers or up to 16-character block mode DMA transfers in DHV11 mode. Single-character or two-character transfers, or up to 16-character block mode DMA transfers in DHU11 mode.
Receive data transfers	Single-character transfers in both DHV11 and DHU11 modes.
Transmit buffer size	One character for DHV11 mode transfers 64-character FIFO for DHU11 mode transfers 64-character FIFO for DMA transfers in DHU11 and DHV11 modes
Receive buffer size	256-character FIFO in DHV11 and DHU11 modes
Supported baud rates	16 programmable baud rates: 50; 75; 110; 134.5; 150; 300; 600; 1200; 1800; 2000; 2400; 4800; 7200; 9600; 19,200; 38,400 <sup>2</sup>
Throughput at maximum baud rate:	
5 data bits, 0 parity, 1 stop bit	140,000 characters/s (all lines)
7 data bits, 1 parity bit, 1 stop bit	110,000 characters/s (all lines)

---

## Configuration Information

---

Form factor	Quad height with integral, recessed cover panel
Power requirements	+5 Vdc, 1.6 A (typ); +12 Vdc, 0.20 A (typ)
Power consumption	10.4 W

<sup>1</sup>Converts a D-connector to a modified modular jack. Required for connecting terminals and printers to office cables terminated with modified modular plugs.

<sup>2</sup>38,400 baud rate is not supported by Digital operating systems.

---

**Configuration Information**

---

Bus loads	3.0 ac; 0.5 dc
Module connectors	2 female, 36-pin Amphenol connectors

---

**Related Documentation**

---

EK-CAB16-UG	CXA16/CXB16 User's Guide
EK-CAB16-TM	CXA16/CXB16 Technical Manual

---



### 2.3.2 CXB16 Asynchronous Multiplexer (16 lines)

The CXB16 is an intelligent, preprogrammed serial controller that can operate in either DHV11 or DHU11 mode, depending on the setting of an on-board switch. The module contains 16 multiplexed lines.

---

#### Functional Information

---

Supported line interfaces	EIA RS-422-A/CCITT V.11 X.27
Split-speed operation	All lines
Flow control (XON/XOFF)	All lines
Supported data formats	16 programmable formats (each with 1 start bit) <ul style="list-style-type: none"><li>• 5, 6, 7, or 8 data bits, 0 or 1 parity bit, and 1 stop bit</li><li>• 5 data bits, 0 or 1 parity bit, and 1.5 stop bits</li><li>• 6, 7, or 8 data bits, 0 or 1 parity bit, and 2 stop bits</li></ul>
Modem control	Parity, if enabled, can be either odd or even. None

---

#### Ordering Information

---

CXB16-AF	Module and cable kit. Includes two 7.6-m (25-ft) BC16D-25 cables, two H3104 cable concentrators, and other accessories required to install the option. <ul style="list-style-type: none"><li>• BC16D-25 cable—data only, 36-conductor, terminated with 36-pin Amphenol male connectors</li><li>• H3104 cable concentrator—concentrates eight BC16E cables into one BC16D cable; eight modified modular jacks and one 36-pin Amphenol female connector</li></ul>
BC16E-series cable	Office cable—data only, six-conductor, terminated with modified modular plugs <ul style="list-style-type: none"><li>• BC16E-10: 3 m (10 ft)</li><li>• BC16E-25: 7.6 m (25 ft)</li><li>• BC16E-50: 15.2 m (50 ft)</li></ul>

---

**Ordering Information**

---

H8572	Cable extender. Null modem cable terminated with modified modular jacks.
-------	--

---

**Performance**

---

Transmit data transfers	Single-character programmed transfers or up to 16-character block mode DMA transfers in DHV11 mode. Single-character or two-character programmed transfers, or up to 16-character block mode DMA transfers in DHU11 mode.
Receive data transfers	Single-character programmed transfers in both DHV11 and DHU11 modes.
Transmit buffer size	One character for programmed transfers in DHV11 mode 64-character FIFO for programmed transfers in DHU11 mode 64-character FIFO for DMA transfers in DHU11 and DHV11 modes
Receive buffer size	256-character FIFO in DHV11 and DHU11 modes
Supported baud rates	16 programmable baud rates: 50; 75; 110; 134.5; 150; 300; 600; 1200; 1800; 2000; 2400; 4800; 7200; 9600; 19,200; 38,400 <sup>1</sup>
Throughput at maximum baud rate:	
5 data bits, 0 parity bits, 1 stop bit	140,000 characters/second (all lines)
7 data bits, 1 parity bit, 1 stop bit	110,000 characters/second (all lines)

---

**Configuration Information**

---

Form factor	Quad height with integral, recessed cover panel
Power requirements	+5 Vdc, 2.0 A (typ); +12 Vdc, 0.00 A (typ)
Power consumption	10.0 W
Bus loads	3.0 ac; 0.5 dc
Module connectors	2 female, 36-pin Amphenol connectors

---

<sup>1</sup>38,400 baud rate is not supported by Digital operating systems.

---

**Related Documentation**

---

EK-CAB16-UG

CXA16/CXB16 User's Guide

EK-CAB16-TM

CXA16/CXB16 Technical Manual

---

### 2.3.3 CXY08 Asynchronous Multiplexer (8 Lines)

The CXY08 asynchronous multiplexer performs data concentration, real-time processing, and interactive terminal handling. The CXY08 can operate in either DHV11 or DHU11 mode, depending on the setting of an on-board switch. The CXY08 supports full modem control.

---

#### Functional Information

---

Supported line interfaces	EIA RS-423-A/CCITT V.10 EIA RS-232-D/CCITT V.28 DEC-423
Split-speed operation	All lines
Flow control (XON/XOFF)	All lines
Supported data formats	16 programmable formats (each with 1 start bit) <ul style="list-style-type: none"><li>• 5, 6, 7, or 8 data bits, 0 or 1 parity bit, and 1 stop bit</li><li>• 5 data bits, 0 or 1 parity bit, 1.5 stop bits</li><li>• 6, 7, or 8 data bits, 0 or 1 parity bit, and 2 stop bits</li></ul>
Modem control	Parity, if enabled, can be either odd or even. Full
Supported modems	Bell models 103, 113, 212

---

#### Ordering Information

---

CXY08-AF	CXY08 field-installed kit. Includes two 3.7-m (12-ft) BC19N-12 cable assemblies and other accessories required to install the option. <ul style="list-style-type: none"><li>• BC19N-12 cable assembly—concentrates four 11-conductor cables with 25-pin male D-connectors into one 44-conductor cable terminated by a 50-pin male CHAMP connector.</li></ul>
----------	--

---

#### Performance

---

Transmit data transfers	Single-character programmed transfers or up to 16-character block mode DMA transfers in DHV11 mode.
-------------------------	---

---

**Performance**

---

Receive data transfers	Single-character or two-character programmed transfers, or up to 16-character block mode DMA transfers in DHU11 mode.
Transmit buffer size	Single-character programmed transfers in both DHV11 and DHU11 modes. One character for programmed transfers in DHV11 mode 64-character FIFO for programmed transfers in DHU11 mode 64-character FIFO for DMA transfers in DHU11 and DHV11 modes
Receive buffer size	256-character FIFO in DHV11 and DHU11 modes
Supported baud rates	16 programmable baud rates: 50; 75; 110; 134.5; 150; 300; 600; 1200; 1800; 2000; 2400; 4800; 7200; 9600; 19,200; 38,400 <sup>1</sup>
Throughput at maximum baud rate:	
5 data bits, 0 parity bits, 1 stop bit	87,771 characters/second (all lines)
7 data bits, 1 parity bit, 1 stop bit	61,440 characters/second (all lines)

---

**Configuration Information**

---

Form factor	Quad height with integral, recessed cover panel
Power requirements	+5 Vdc, 1.64 A (typ); +12 Vdc, 0.395 A (typ)
Power consumption	12.94 W
Bus loads	3.0 ac; 0.5 dc
Module connectors	2 female, 50-pin CHAMP connectors

---

**Related Documentation**

---

EK-CXY08-UG	CXY08 User's Guide
EK-CXY08-TM	CXY08 Technical Manual

---

<sup>1</sup>38,400 baud rate is not supported by Digital operating systems.

---

### 2.3.4 DESQA Ethernet Controller

The DESQA Ethernet controller provides a high-speed asynchronous connection between a Q22-bus system and a Local Area Network (LAN) based on Ethernet or IEEE 802.3. The DESQA supports either standard or ThinWire Ethernet cabling.

---

#### Functional Information

---

Supported protocols	Ethernet, IEEE 802.3 Maintenance Operation Protocol (MOP)
---------------------	--

---

#### Ordering Information

---

DESQA-SF	DESQA field-installed kit
External cable (standard)	BNE3B or BNE3D
External cable (ThinWire)	BC16M

---

#### Performance

---

Transmit/Receive data transfers	Up to 32-byte block mode DMA
Transmit data transfers	2-Kbyte FIFO for DMA transfers
Receive data transfers	4-Kbyte FIFO for DMA transfers
Throughput at maximum rate	10 Mbits/second

---

#### Configuration Information

---

Form factor	Quad height
Power requirements	+5 Vdc, 2.4 A; +12 Vdc, 0.22 A
Power consumption	14.64 W
Bus loads	2.2 ac; 0.5 dc
Module connectors (standard)	One 15-pin D-type
Module connectors (Thinwire)	T-connector to BNC connector on DESQA

---

#### Related Documentation

---

EK-DESQA-TM	DESQA Technical Manual
-------------	------------------------

---

### 2.3.5 DEQRA Token Ring Q-bus Adapter

The DEQRA Token Ring Q-bus adapter and its software, TRDRV/VMS, enable Q-bus VAX systems to connect to 4- or 16-Mbits/second Token Ring networks, and to act as full function DECnet Phase IV nodes and pathworks for VMS servers.

---

#### Functional Information

---

Supported protocols	IBM-compatible Token Ring (IEEE 802.5)
Operating system supported	VMS 5.4 DECTRN Driver VMS 1.0

---

#### Ordering Information

---

DEQRA-CA	DEQRA module, documentation, and licensed letter
BC29E-15	External console ribbon cable, 15-ft
OL-GVJAP-AA	Software license

---

#### Performance

---

Data transfer rate	4-Mbits and 16-Mbits
--------------------	----------------------

---

#### Diagnostic Support

---

Diagnostic support	Power-on self test MDM Installation Verification Procedure DEQRA specific from host
--------------------	--

---

#### Configuration Information

---

Form factor	Quad height
Power requirements	+5 Vdc, 4.0 A; +12 Vdc, 0.1 A
Power consumption	21.2 W
Bus loads	2.2 ac; 0.5 dc

---

**Related Documentation**

---

EK-DEQRA-IN	DECTRN Controller 100 Hardware Installation
EK-DEQRA-TM	DECTRN Controller 100 Hardware Description
AA-PH7NA-TE	DECTRN Device Driver for VMS Installation
AA-PH7PA-TE	DECTRN Device Driver for VMS Use and Programming

---



### 2.3.6 DFA01 Asynchronous Controller with Integral Modem

The DFA01 is an asynchronous serial controller that emulates the DZQ11. It has two lines, each with a DF224-compatible integral modem.

---

#### Functional Information

---

Supported modulation protocols	Bell 103J Bell 212A CCITT V.22 CCITT V.22-BIS
Split-speed operation	Both lines
Flow control (XON/XOFF)	No
Supported data formats	8 programmable formats (each with 1 start bit) <ul style="list-style-type: none"><li>• 5, 6, 7, or 8 data bits, 0 or 1 parity bit, and 1 stop bit</li><li>• 5, 6, 7, or 8 data bits, 0 or 1 parity bit, and 2 stop bits</li></ul>
Modem control	Full

---

#### Ordering Information

---

DFA01-AF	Field-installed kit
----------	---------------------

---

#### Performance

---

Transmit data transfers	Single-character programmed transfers
Receive data transfers	Single-character programmed transfers
Transmit buffer size	One character for programmed transfers
Receive buffer size	64-character FIFO
Supported baud rates	8 programmable baud rates: 50, 75, 110, 134.5, 150, 300, 1200, 2400 <sup>1</sup>
Throughput at maximum baud rate	1200 bytes/second

---

<sup>1</sup>The serial line is capable of baud rates up to 9600 baud. However, because the modem is restricted to speeds of 0-300, 1200, and 2400 baud, all other baud rates are considered illegal and pass meaningless data.

---

**Configuration Information**

---

Form factor	Quad height with integral, flush cover panel
Power requirements	+5 Vdc, 1.97 A; +12 Vdc, 0.04 A
Power consumption	10.30 W
Bus loads	3.0 ac; 1.0 dc
Module connectors	4 TELCO: 2 modified modular jacks (MMJ) for data lines; 2 modular jacks (MJ) for voice lines

---

**Related Documentation**

---

EK-DFA01-UG	DFA01 Modem User's Guide
EK-DFA01-IN	DFA01 Modem Installation Guide

---

### 2.3.7 DPV11 Synchronous Controller

The DPV11 is a single-line programmable controller that provides local or remote interconnections between systems.

---

#### Functional Information

---

Supported line interfaces	EIA RS-232-C/CCITT V.28 EIA RS-423-A EIA RS-422-A
Supported protocols	DDCMP, BISYNC, and SDLC
Operating mode	Full or half-duplex
Character size	Program selectable (5-8 bits with character-oriented protocols and 108 bits with bit-oriented protocols)
Modem support	Limited
Supported modems	All Digital modems and the Bell 200 series

---

#### Ordering Information

---

DPV11-SF	Field-installed kit
----------	---------------------

---

#### Performance

---

Transmit/Receive data transfers	Single-byte programmed transfer
Transmit buffer size	2 bytes
Receive buffer size	2 bytes
Data rate	56 Kbits/second

---

#### Configuration Information

---

Form factor	Dual height
Power requirements	+5 Vdc, 1.2 A (typ); +12 Vdc, 0.3 A (typ)
Power consumption	9.6 W
Bus loads	1.0 ac; 1.0 dc

---

#### Related Documentation

---

EK-DPV11-UG	DPV11 Synchronous Interface User's Guide
EK-DPV11-TM	DPV11 Technical Manual

---

### 2.3.8 DSRVB DECserver 200

The DSRVB DECserver 200 is an 8-line terminal server used to connect terminals to a host computer on an Ethernet Local Area Network (LAN). Software for the server is downline-loaded from a host to the server. The server is available in two models: the modem control (MC) model has modem control and an RS-232-C line interface; the data leads (DL) model has no modem control and a DEC-423 (DECconnect) line interface.

---

#### Functional Information

---

Supported line interfaces	RS-232-C (MC Model)/DEC-423 (DL Model)
Modem control	Yes (MC Model)/No (DL Model)
Protocols	Asynchronous
Supported terminal devices	VT-, LN-, LA-, and LQ-series devices

---

#### Ordering Information (hardware only)<sup>1</sup>

---

DSRVB-AA	8-line DECserver 200/MC, RS-232-C line interface, 120 V. Includes country kit. <sup>2</sup>
DSRVB-BA	8-line DECserver 200/DL, DEC-423 (DECconnect) line interface, 120 V. Includes country kit.
DSRVB-AB	8-line DECserver 200/MC, RS-232-C line interface, 240 V. Requires country kit.
DSRVB-BB	8-line DECserver 200/DL, DEC-423 (DECconnect) line interface, 240 V. Requires country kit.

---

#### Performance

---

Maximum throughput	8 lines at 19.2 Kbytes/second
--------------------	-------------------------------

---

#### Physical Specifications

---

Height	11.75 cm (4.63 in)
Width	48.90 cm (19.25 in)
Depth	32.07 cm (12.63 in)
Weight	5.44 kg (12 lb)

---

<sup>1</sup>See the *Networks and Communications Buyer's Guide* for appropriate software.

<sup>2</sup>Each country kit includes a power cord, hardware manual, and rack mounting brackets. See the *Networks and Communications Buyer's Guide* for available country kits.

---

**Related Documentation**

---

AA-HL77B-TK

DSRVB DECserver 200 User's Guide

---

### 2.3.9 DSV11 Synchronous Controller

The DSV11 is a two-channel, high-speed, synchronous controller that interfaces Q22-bus backplanes.

---

#### Functional Information

---

Supported line interfaces	RS-423 RF-422 RS-232/V.24, V.35
Supported protocols	DDCMP HDLC/SDLC BISYNC
Operating mode	Full or half-duplex
Modem support	Full modem control

---

#### Ordering Information

---

DSV11-SF	Field-installed kit (first DSV11)
DSV11-SG	Field-installed kit (additional DSV11s)

---

#### Performance Information

---

Transmit/Receive data transfers	DMA
Data rate, Mbits/second (maximum)	RS-232-C/V.24 = up to 20K RS-423 = 100K RS-422 = 256K V.35 = 48K

---

#### Configuration Information

---

Form factor	Quad height
Power requirements	+5 Vdc, 5.43 A (typ); 12 Vdc, 0.69 A (typ)
Power consumption	35.43 W
Bus loads	3.9 ac; 1.0 dc

---

#### Related Documentation

---

EK-DSV11-UG	DSV11-S Communications Option User Guide
EK-DSV11-TD	DSV11 Communications Option Technical Description

---

## 2.4 Real-Time Options

Real-time controllers interface devices that monitor processes in environments such as the laboratory or manufacturing. Typically, real-time controllers are parallel devices that transmit more than one bit of information simultaneously.

The VAX 4000 Model 200 system supports the following real-time options:

- AAV11-S digital-to-analog converter
- ADQ32 analog-to-digital converter
- ADV11-S analog-to-digital converter
- AXV11 controller
- DIV32 controller
- DRQ3B parallel interface
- DRV1W parallel interface
- IBQ01 controller
- IEQ11 controller
- K WV11-S programmable real-time clock

## 2.4.1 AAV11–S Digital-to-Analog Converter

The AAV11–S is a digital-to-analog converter with DMA capability. The AAV11–S is functionally equivalent to the AAV11–D.

---

### Functional Information

---

Circuits	Two D/A converter circuits
D/A input	12-bit digital input
Data notation	Binary input notation for unipolar output; offset binary or two's complement input notation for bipolar output.
D/A output	
Voltage	Output voltage range is jumper selectable: $\pm 10$ V, $\pm 5$ V, or 0 V to +10 V.
Control signals	4-bit digital output for control signals, such as CRT intensity, blank, unblank, and erase
Polarity	Unipolar or bipolar output

---

### Ordering Information

---

AAV11–SF	AAV11–S field-installed kit
UDIP–BA <sup>1</sup>	Universal data interface panel (UDIP) mounting box
UDIP–DB	Universal data interface panel (UDIP)
UDIP–TA	Tabletop enclosure

---

### Performance

---

Analog output	
Voltage	$\pm 10$ V, at 10 mA $\pm 5$ V, at 10 mA 0 V to 10 V, at 10 mA
Current	10 mA, at 10 V minimum
DC impedance	0.05 $\Omega$ typical
Linearity (0–10 V)	$\pm 1/2$ LSB; $\pm 1.2$ mV at full-scale range
Differential linearity	$\pm 1/2$ LSB
Offset error	Adjustable to 0
Offset drift	$\pm 15$ ppm/at maximum $^{\circ}\text{C}$
Gain accuracy	Adjustable to zero
Gain drift	$\pm 25$ ppm/at maximum $^{\circ}\text{C}$
Settling time	6 $\mu\text{s}$ to 0.1% for a p–p output change of 20 V

---

<sup>1</sup>You must order both the UDIP mounting box and the UDIP interface when installing a new option.



---

**Configuration Information**

---

Form factor	Dual height
Power requirements	+5 Vdc, 2.10 A (typ); +12 Vdc, 0.0 A
Power consumption	10.5 W
Bus loads	2.5 ac; 0.5 dc

---

**Related Documentation**

---

EK-AV11D-UG	Q-Bus DMA Analog System User's Guide
-------------	--------------------------------------

---

## 2.4.2 ADQ32 Analog-to-Digital Converter

The ADQ32 is an analog-to-digital converter with DMA capability.

---

### Functional Information

---

Input channels	32 single-ended analog input channels or 16 differential analog input channels; single-ended or differential is programmable
Programmable gain	1, 2, 4, or 8; selectable per channel
A/D output	
Resolution	12-bit output data resolution
Data notation	Straight binary (unipolar), two's complement (bipolar)
A/D conversions	Can be started by a program, a real-time clock, or an external trigger
A/D results	Can be received by a programmed I/O transfer or by servicing an interrupt request
Interrupts	Can be enabled and automatically set
Common mode rejection ratio	55 dB at maximum range

---

### Ordering Information

---

ADQ32-SF	ADQ32 field-installed kit
UDIP-BA <sup>1</sup>	Universal data interface panel (UDIP) mounting box
UDIP-AA	Universal data interface panel (UDIP)
UDIP-TA	Tabletop enclosure

---

### Performance

---

Analog input	
No. of analog inputs	16 channels using differential inputs or 32 channels using single-ended inputs
Input range	0 V to +10 V (unipolar); -10 V to +10 V (bipolar)
Input impedance	10 M $\Omega$ , minimum
Input bias current	500 nA maximum ON current
Input protection	Inputs are current-limited and protected to an overvoltage of $\pm 35$ V without damage.
Common mode rejection ratio	55 dB

---

<sup>1</sup>You must order both the UDIP mounting box and the UDIP interface when installing a new option.

---

**Performance**

---

A/D output	
Data buffer register	16-bit read-only output register
Resolution	12 bits unipolar; 11 bits bipolar plus sign bit
Data notation	Straight binary or two's complement
Sample and hold amplifier	
Aperture uncertainty	1 nanosecond
Aperture delay	50 nanoseconds, maximum with minimum aperture enabled (clock bypass bit set)
Input noise	2 $\mu$ V p-p
A/D converter performance	
Linearity	
Differential	0.2 to 2 LSB
Integral	1.5 LSB, maximum
Scale drift	15 ppm/C typical

---

**Performance**

---

System throughput	
Maximum single channel sample rate	250 KHz
Maximum multichannel rate to ensure $\pm 1/2$ LSB accuracy	200 KHz

---

**Configuration Information**

---

Form factor	Quad height
Power requirements	+5 Vdc, 4.45 A (typ); +12 Vdc, 0.0 A
Power consumption	22.25 W
Bus loads	2.5 ac; 0.5 dc

---

**Related Documentation**

---

EK-153AA-UG	ADQ32 Analog-to-Digital Converter User's Guide
-------------	--

---

### 2.4.3 ADV11–S Analog-to-Digital Converter

The ADV11–S is an analog-to-digital converter with DMA capability. The ADV11–S is functionally equivalent to an ADV11–D.

---

#### Functional Information

---

Input channels	16 single-ended analog input channels or 8 differential analog input channels; SE/DI input is jumper-selectable.
Programmable gain	1, 2, 4, or 8
A/D output	
Resolution	12-bit output data resolution
Data notation	Binary, offset binary, or two's complement
A/D conversions	Can be started by a program, a real-time clock, or an external trigger
A/D results	Can be received by a programmed I/O transfer or by servicing an interrupt request
Interrupts	Can be enabled and automatically set by A/D DONE and/or ERROR bits
Common mode rejection ratio (gain=1)	80 dB at maximum range

---

#### Ordering Information

---

ADV11–SF	ADV11 field-installed kit
UDIP–BA <sup>1</sup>	Universal data interface panel (UDIP) mounting box
UDIP–AB	Universal data interface panel (UDIP) for ADV11–S
UDIP–TA	Tabletop enclosure

---

#### Performance

---

Analog input	
No. of analog inputs	8 channels using differential inputs or 16 channels using single-ended inputs
Input range	0 V to +10 V (unipolar) –10 V to +10 V (bipolar)
Maximum input signal	±10.5 V (signal + common mode voltage)
Input impedance	
Off channels	100 M $\Omega$ minimum, 10 pF maximum
On channels	100 M $\Omega$ minimum, 100 pF maximum

---

<sup>1</sup>You must order both the UDIP mounting box and the UDIP interface when installing a new option.

---

**Performance**

---

Power off	1 K $\Omega$ in series with a diode
Input bias current	$\pm 20$ nA at 25°C (77°F) maximum
Input protection	Inputs are current-limited and protected to an overvoltage of $\pm 35$ V without damage.
Common mode rejection ratio	80 dB at a range of $\pm 10$ V at 60 Hz
A/D output	
Data buffer register	16-bit read-only output register
Resolution	12 bits unipolar; 11 bits bipolar plus sign bit
Data notation	Binary, offset binary, or two's complement
Sample and hold amplifier	
Aperture uncertainty	Less than 10 nanoseconds
Aperture delay	Less than 0.5 $\mu$ s from start of conversion to signal disconnect
Front end settling	Less than 15 $\mu$ s to $\pm 0.01\%$ of full-scale value for a peak-to-peak input of 20 V
Input noise	Less than 0.2 mV rms
A/D converter performance	
Linearity	Less than $\pm 1/2$ LSB
Stability (temperature coefficient)	$\pm 30$ ppm at maximum °C (32°F)
Stability (long term)	$\pm 0.05\%$ change in 6 months
System accuracy (gain=1)	Input voltage to digitized value to within $\pm 0.03\%$
System throughput	25K channel samples/second

---

**Configuration Information**

---

Form factor	Dual height
Power requirements	+5 Vdc, 2.0 A (typ); +12 Vdc, 0.0 A
Power consumption	10.0 W
Bus loads	2.3 ac; 0.5 dc

---

**Related Documentation**

---

EK-AV110-UG	Q-Bus DMA Analog System User's Guide
-------------	--------------------------------------

---

## 2.4.4 AXV11 Controller

The AXV11-S is an input/output circuit board for analog devices. The AXV11-S is functionally equivalent to the AXV11-C.

---

### Functional Information

---

Input channels	16 single-ended analog input channels or 8 differential analog input channels; SE/DI jumper is field-selectable.
Programmable gain	1, 2, 4, or 8
A/D output	
Data resolution	12-bit output data resolution
Data notation	Binary, offset binary, or two's complement
Voltage	Output voltage range selection of $\pm 10$ V (bipolar) or 0 V to 10 V (unipolar)
A/D conversions	Can be started by a program, an external trigger, or a real-time clock
A/D results	Can be received by a programmed I/O transfer or by servicing an interrupt request
Common mode rejection ratio	80 dB at maximum range
D/A converters (DACs)	
No. of DACs	2
Input (each DAC)	12-bit digital input
Output (each DAC)	Unipolar or bipolar output

---

### Ordering Information

---

AXV11-SF	AXV11 field-installed kit
UDIP-BA <sup>1</sup>	Universal data interface panel (UDIP) mounting box
UDIP-AY	Universal data interface panel (UDIP) for AXV11-S
UDIP-TA	Tabletop enclosure

---

### Performance

---

A/D converter performance	
Linearity	To within $\pm 1/2$ LSB
Stability (temperature coefficient)	$\pm 30$ ppm at maximum $^{\circ}\text{C}$ ( $32^{\circ}\text{F}$ )
Stability (long term)	$\pm 0.05\%$ change in 6 months
Conversion time	25 $\mu\text{s}$ from end of front end settling to setting the A/D DONE bit

---

<sup>1</sup>You must order both a UDIP mounting box and an interface when installing a new option.

---

**Performance**

---

System throughput	25K channel samples/second
D/A converter specifications	
No. of D/A converters	2
Digital input	12 bits (Binary code is used for unipolar output; offset binary or two's complement code is used for bipolar output.)
Analog output	±10 V (bipolar) or 0 V to +10 V (unipolar)
Output current	±5 mA maximum
Output impedance	0.1 $\Omega$
Differential linearity	To within ±1/2 LSB
Nonlinearity	0.02% of full-scale value
Offset error	Adjustable to 0
Offset drift	±30 ppm at maximum °C (32°F)
Gain accuracy	Adjustable to full-scale value
Gain drift	±30 ppm at maximum °C (32°F)
Settling time	65 $\mu$ s to 0.1% for a peak-to-peak output change of 20 V
Noise	0.1% full-scale value
Capacitive load capability	0.5 $\mu$ F

---

**Configuration Information**

---

Power requirements	+5 Vdc, 2.0 A; +12 Vdc, 0.0 A
Power consumption	10.0 W
Bus loads	1.2 ac; 0.3 dc

---

**Related Documentation**

---

EK-AXVAA-UG	AXV11/KWV11 Module User's Guide
MP-O11291-00	AXV11-C Field Maintenance Print Set

---

## 2.4.5 DIV32 Controller

The DIV32 is a quad-height, integrated services digital network (ISDN) communications controller with connection to the Q22-bus backplane.

---

### Functional Information

---

Supported line interfaces	RS-423 RS-422 RS-232/V.24, V.35
Supported protocols	VAX ISDN
Operating mode	Full- or half-duplex

---

### Ordering Information

---

DIV32-SA	Factory-installed
DIV32-SF	Field-installed kit

---

### Performance

---

Transmit/Receive data transfers	DMA
Data transfer rate	64 Kbits/second

---

### Configuration Information

---

Form factor	Quad height
Power requirements	+5 Vdc, 5.5 A (typ)
Power consumption	27.5 W
Bus loads	3.9 ac; 1.0 dc

---

### Related Documentation

---

EK-DIV32-UG	Communications Option User Guide
EK-DIV32-IN	DIV Hardware Installation Guide

---



## 2.4.6 DRQ3B Parallel Interface

The DRQ3B is a high-speed parallel interface that provides two independent 16-bit, unidirectional data channels.

---

### Functional Information

---

Two unidirectional channels	Each 512-word FIFO
Interrupt vectors	One for both DMA channels One for all other interrupts

---

### Ordering Information

---

DRQ3B-SF	Field-installed kit
Cables	Connects the DRQ3B to a user device or to another DRQ3B. Order two cables for each DRQ3B module. BC19T-25/-50: 7.6 m (25 ft)/15.2 m (50 ft)

---

### Performance

---

Throughput rates	Burst: 500 kilowords Block: 1.1 megawords Extended block mode: 1.1 megawords Height speed: 1.4 megawords
------------------	---

---

### Configuration Information

---

Form factor	Quad height
Power requirements	+ 5 Vdc, 4.5 A; +12 Vdc, 0.0 A
Power consumption	22.5 W
Bus loads	2.0 ac; 0.5 dc
Module connectors	Two 50-pin female IEEE connectors
I/O port data transceivers	Source 16 mA, sink 64 mA

---

### Related Documentation

---

EK-O47AA-UG	DRQ3B Parallel DMA Input/Output Module User's Guide
-------------	---

---

## 2.4.7 DRV1W Parallel Interface

The DRV1W is a general-purpose, parallel interface with one 16-bit input port and one 16-bit output port. The DRV1W supports DMA. The DRV1W-S is functionally equivalent to the DRV11-WA.

---

### Functional Information

---

Number of lines	Total: 50 16 data output lines 16 data input lines 3 user-definable input status lines 3 user-definable output control lines 8 input control lines 4 output control lines
Line characteristics	
Input data lines	1 TTL unit load each
Input control lines	1 TTL unit load each
Output data lines	10 TTL unit loads each
Output control lines	10 TTL unit loads each
Logic levels	High = logic 1 Low = logic 0

---

### Ordering Information

---

DRV1W-SF	Field-installed kit
----------	---------------------

---

### Performance

---

Transfer mode	Up to 2-byte programmed transfers Up to 8-byte burst mode DMA transfers and unlimited burst mode DMA transfers (unsupported)
Data transfer rate	Up to 250,000 16-bit words/second in single-cycle mode Up to 500,000 16-bit words/second in burst mode

---

### Configuration Information

---

Form factor	Dual height
Power requirements	+5 Vdc, 1.8 A (typ); +12 Vdc, 0.0 A
Power consumption	9.0 W
Bus loads	2.0 ac; 1.0 dc

---

**Configuration Information**

---

Module connectors                      Two 40-pin connectors

---

**Related Documentation**

---

EK-DRVWA-UG                      DRV11-WA General Purpose DMA User's Guide

---

## 2.4.8 IBQ01 Controller

The IBQ01 is a DMA controller that interfaces a Q22-bus system to RS-485 industrial control and measurement devices.

---

### Functional Information

---

Communication protocol	Modified SDLC
Supported functions	Single multidrop interconnect 250 BITBUS compatible devices

---

### Ordering Information

---

IBQ01-SF	Field-installed kit
Cables	User-supplied RS-485 BITBUS standard

---

### Performance

---

Transfer mode	Programmed I/O transfers with interrupt DMA data transfer
Data transfer rate	Up to 2.4 Mbits/second at BITBUS length of 30 m 375 Kbits/second at BITBUS length of 300 m 62.5 Kbits/second at BITBUS length of 13,200 m

---

### Configuration Information

---

Form factor	Quad height
Power requirements	+5 Vdc, 5.0 A; +12 Vdc, 0.3 A
Power consumption	28.6 W
Bus loads	4.6 ac; 1.0 dc

---

### Related Documentation

---

EK-IBQ01-UG	DECscan BITBUS Controller User's Guide
EK-IBQ01-IN	DECscan BITBUS Controller Installation Manual
EK-IBQ01-TM	DECscan BITBUS Controller Technical Manual
EK-JQ52A-TN	DECscan BITBUS Controller Software Installation

---

## 2.4.9 IEQ11 Controller

The IEQ11 option is a DMA controller that interfaces a Q22-bus system to two independent instrument buses (IEC/IEEE).

---

### Functional Information

---

Supported interfaces	IEEE-488-1978 IEC 625-1
Supported interface functions	Automatic source handshake Automatic acceptor handshake Talker and extended talker (includes serial poll) Listener and extended listener Service request Remote local Parallel poll Device clear/Device trigger Controller

---

### Ordering Information

---

IEQ11-SF	Field-installed kit for IEC connection
----------	--

---

### Performance

---

Transfer mode	Programmed I/O transfers with interrupt DMA data transfers
Data transfer rate	150 Kbytes/s during a DMA block transfer

---

### Configuration Information

---

Form factor	Quad height
Power requirements	+5 Vdc, 3.5 A (typ); +12 Vdc, 0.0 A
Power consumption	17.5 W
Bus loads	2.0 A ac; 1.0 A dc
Module connectors	Standard 24-pin IEEE 488 connector (IEQAA-AC) Standard 25-pin IEC 625 connector (IEQ11-AD)

---

### Related Documentation

---

EK-IEUQ1-UG	IEU11-A/IEQ11-A User's Guide
-------------	------------------------------

---

## 2.4.10 KWV11–S Programmable Real-Time Clock

The KWV11–S is a programmable real-time clock that can be programmed to count from one to five crystal-controlled frequencies, from an external frequency or event, or from a 50-Hz or 60-Hz line frequency on the Q22-bus. The board can generate interrupts or can synchronize the processor to external events. The KWV11–S clock is functionally equivalent to the KWV11–C.

---

### Functional Information

---

Resolution	16 bits
Frequencies	5 internal crystal frequencies — 1 MHz, 100 kHz, 10 kHz, 1 kHz, and 100 Hz
Schmitt Triggers	2, each with slope and level controls that can be used to start the clock or generate program interrupts
Input	Line freq input from BEVNT bus (50 or 60 Hz)
Modes	4 programmable modes

---

### Ordering Information

---

KWV11–SF	Field-installed kit
UDIP–BA <sup>1</sup>	Universal data interface panel mounting box
UDIP–KB	Universal data interface panel for KWV11–S
UDIP–TA	Tabletop enclosure

---

### Performance

---

Clock	
Crystal oscillator	10-MHz base frequency
Output ranges	1 MHz, 100 kHz, 10 kHz, 1 kHz, and 100 Hz
Oscillator accuracy	0.01%
Other sources	Line frequency or input at Schmitt Trigger
Schmitt-Trigger input signals	
No. of inputs	2
Input range	±30 V (maximum limits)
Triggering range	–12 V to +12 V (adjustable)
Triggering slope	Positive or negative, switch-selectable
Source	User device
Response time	Depends on input waveform and amplitude; for TTL logic levels, typically 600 nanoseconds

---

<sup>1</sup>You must order both a UDIP mounting box and an interface when installing a new option.

---

**Performance**

---

Hysteresis	Approximately 0.5 V, positive and negative
Characteristics	Single-ended input, 100-K $\Omega$ impedance to gnd
Clock output	
Signal	CLK OV L (clock overflow, asserted low)
Output pins	J1 pin 5 and CLK OVFL tab
Function	Time base selection from an internal crystal-controlled frequency, an input at ST1, or a line frequency at BEVNT bus line
Duration	Approximately 500 nanoseconds
Line driver	TTL-compatible, open collector circuit with a 470- $\Omega$ pull-up resistor to +5 V
Maximum source current	5 mA when output is high ( $\geq 2.4$ V), measuring from source through load to ground
Maximum sink current	8 mA when output is low ( $\leq 0.8$ V), measuring from external source voltage through load to output
Schmitt-Trigger 1 output	
Signal	ST1 OUT L (asserted low)
Output pins	J1 pin 2 and ST1 OUT tab
Function	External time base input or counter. Input frequency is a function of the input signal.
Other characteristics	Same as clock output
Schmitt-Trigger 2 output	
Signal	ST2 OUT L (asserted low)
Output pin	J1 pin 4
Function	Starts counter, sets ST2 flag, and generates an interrupt (if enabled); causes buffer preset register (BPR) to be loaded from counter.
Other characteristics	Same as clock output

---

**Configuration Information**

---

Power requirements	+5 Vdc, 2.2 A (typ); +12 Vdc, 0.013 A (typ)
Power consumption	11.156 W
Bus loads	1.0 ac; 0.3 dc

---

**Related Documentation**

---

EK-AXVAA-UG	AXV11/KWV11 Module User's Guide
-------------	---------------------------------

---

## 2.5 Printer Interface

### 2.5.1 LPV11–SA Printer Interface

The LPV11 printer interface controls the flow of data between the Q22-bus and a line printer.

---

#### Ordering Information

---

LPV11–SA	LPV11 controller module
----------	-------------------------

---

#### Configuration Information

---

Form factor	Quad height
Power requirements	+5 Vdc, 2.8 A (typ); +12 Vdc, 0.0 A
Power consumption	14.0 W
Bus loads	1.8 ac; 0.5 dc
Module connectors	2 female, 37-pin D subminiature connectors

---

#### Related Documentation

---

EK–LPV11–OP	LPV11 Printer User's Manual
-------------	-----------------------------

---



## 2.6 Graphics Adapters

### 2.6.1 VS30U Graphics Adapter

The VS30U is a full-page, high-resolution DMA color video subsystem capable of 8-plane color video memory display. The VS30U allows field upgrade of Q-bus VAXservers to Q-bus workstations. The option includes the 8-plane color graphics module set (VCB02-J) as well as the 19-in color monitor (VR299) and a keyboard, mouse, and cable.

---

#### Ordering Information

---

VS30U	3 modules: base module and two 4-plane modules
VS30U-G3	GPX upgrade for BA213, VR299, 240 V
VS30U-G4	GPX upgrade for BA213, VR299, 240 V SH
VS30U-GA	GPX upgrade for BA213, VR299, 120 V

---

#### Configuration Information

---

Form factor	Quad height
Power requirements	Base module at +5 Vdc, 5.8 A (typ)
	Base module at +12 Vdc, 0.7 A (typ)
	4-plane module at +5 Vdc, 3.4 A (typ)

---

## Chapter 3

# System Expansion

---

This chapter provides guidelines on how to expand your VAX 4000 Model 200 system.

### 3.1 Planning System Expansion

You must consider the following when you decide to expand your system:

- Can your system accommodate additional supported options?  
You determine this by filling in the appropriate worksheet (Figure 3–1 or Figure 3–2) with the options currently installed in your system and those you wish to add.
- If your existing system cannot accommodate a particular set of supported options, you might wish to add one of the following expanders, to enable support for the RA-series or RF-series ISEs.

**NOTE:** *When combining BA215 and BA430 enclosures in the same VAXcluster, you must use grounding kit H4010-AA.*

---

<b>Expander Name</b>	<b>Additional Q-22-Bus Slots</b>	<b>Additional Storage Capacity</b>
B213F	11	Up to three RF-series ISEs.
R215F	0	Up to three RF-series ISEs.
B400X	11	Up to four RF-series disk drives or three tape drives and one TK or TF series tape drive.
R400X	0	Up to seven RF-series disk drive or six RF-series ISEs, with room for one TLZ04 tape drive.

---

This chapter does not describe how to configure new options or how to install them in your system. Configuring an option involves assigning a control and status register (CSR) address and an interrupt vector. This is usually done

by means of switches or jumpers on the options themselves. Digital service representatives configure the options when they install them. Your Digital service representative also determines the proper placement of options within your system, according to specific guidelines.

## 3.2 Completing the VAX 4000 Model 200 Configuration Worksheets

To determine what options you can add to your system, you must list the options currently installed and their power requirements on the appropriate VAX 4000 Model 200 Configuration Worksheet, provided in Figure 3-1 and Figure 3-2.

The worksheet in Figure 3-1 is for the BA430 enclosure. All backplane slots and mass storage devices are powered by the H7874 power supply. The worksheet in Figure 3-2 is for the BA215 enclosure.

Use the worksheets as follows:

1. In the Module column, list all options and mass storage devices currently installed in your system, except the controller for the tape drive. The processor module, one memory module, and the tape drive has already been entered.

Use the label on the cover panel of each slot to identify the module installed in that slot.

2. List each RF-series ISE.
3. List the options and mass storage devices you wish to add to your system.
4. List the controller for the tape drive last.
5. Fill in the power requirements for each module and each mass storage device. The power requirements for the more common options are listed in Table 3-1; refer to the option descriptions in Chapter 2 for the power requirements of additional options.
6. Add each column and make sure the totals do not exceed the specified limit. As long as the figures are within range, you can probably install the new option(s).

**NOTE:** *The worksheets are only guides. Confirm your plan with your Digital sales representative. While certain configurations may be possible, they may not be recommended due to excessive loads on the system or difficulties in arranging bus and cable access to all devices.*

**Figure 3–1: VAX 4000 Model 200 (BA430 Enclosure) Configuration Worksheet**

Slot	Module	Current (Amps)				Power (Watts)	Bus Load	
		+5 Vdc	+12 Vdc	+3.3 Vdc	12 Vdc		AC	DC
0								
CPU 1								
Mem 2								
Mem 3								
Mem 4								
Mem 5								
Q/CD 6								
Q/CD 7								
Q/CD 8								
Q/CD 9								
Q/CD 10						—	—	
Q/CD 11								
Q/CD 12								
<b>Mass Storage:</b>								
Tape							—	—
1								
2								
3								
Total these columns:								
Must not exceed:		60.0 A	22.0 A	15.0 A	3.0 A	584.0 W	31	20

Note: Total output power from +3.3 Vdc and +5 Vdc must not exceed 330 W.

MLO-005711

**Figure 3-2: VAX 4000 Model 200 (BA215 Enclosure) Configuration Worksheet**

**Primary Power Supply**

Slot	Module	Current (Amps)		Power (Watts)	Bus Load	
		+5 Vdc	+12 Vdc		AC	DC
CPU 1						
Mem 2						
Q/CD 3						
Q/CD 4						
Q/CD 5						
Q/CD 6						
<b>Mass Storage:</b>						
Tape Drive						
Fixed Disk 0						
Fixed Disk 1						
Total these columns:						
Must not exceed:		33.0 A	7.6 A	230.0 W		

MLO-005712

**Table 3–1: Power Requirements**

Option	Module	Current (Amps) Max		Power Max	Bus Loads	
		+5 V	+12 V	Watts	AC	DC
AAV11-SA	A1009-PA	2.10	0.00	10.50	2.5	0.5
ADQ32-SA	A030	4.45	0.00	22.25	2.5	0.5
ADV11-SA	A1008-PA	2.00	0.00	10.00	2.3	0.5
AXV11-SA	A026-PA	2.00	0.00	10.00	1.2	0.3
CXA16-AA	M3118-YA	1.60	0.20	10.40	3.0	0.5
CXB16-AA	M3118-YB	2.00	0.00	10.00	3.3	0.5
CXY08-AA	M3119-YA	1.64	0.395	12.94	3.0	0.5
DESQA-SA	M3127-PA	2.40	0.22	14.64	3.3	0.5
DFA01-AA	M3121-PA	1.97	0.04	10.30	3.0	1.0
DIV32-SA  B	M7571-PA	5.5	0.00	35.4	3.5	1.0
DPV11-SA	M8020-PA	1.20	0.30	9.60	1.0	1.0
DRQ3B-SA	M7658-PA	4.50	0.00	22.50	2.0	0.5
DRV1J-SA	M8049-PA	1.80	0.00	9.00	2.0	1.0
DRV1W-SA	M7651-PA	1.80	0.00	9.00	2.0	1.0
DSV11-SA	M3108	5.43	0.69	35.43	3.9	1.0
H3602	-	0.30	0.50	6.50	-	-
H3604 <sup>1</sup>	-	1.70	0.50	14.50	-	-
IBQ01-SA	M3125-PA	5.00	0.30	28.60	4.6	1.0
IEQ11-SA	M8634-PA	3.50	0.00	17.50	2.0	1.0
KA660-AA/BA <sup>4</sup>	M7626-AA/BA	4.8	0.55	30.60	4.0	1.0
KDA50-SE	M7164	6.93	0.00	34.65	3.0	0.5
—	M7165	6.57	0.03	33.21	-	-
KFQSA-SA/SE	M7769	5.50	0.00	27.50	4.4	0.5
KLESI-SA/SF	M7740-PA	4.00	0.00	20.00	0.5	1.0
KRQ50-SA	M7552	2.70	0.00	13.50	2.7	1.0
KWV11-SA	M4002-PA	2.20	0.013	11.156	1.0	0.3
KXJ11-SF	M7616	6.0	0.7	46.8	2.0	1.0
KZQSA-SA/SF	M5976	5.4	0.0	27.0	4.4	0.5
LPV11-SA	M8086-PA	2.80	0.00	14.00	1.8	0.5
M9404-PA	M9404	-	0.00	0.0	-	-
M9405-PA	M9405	-	0.00	0.0	-	-
MRV11-D	M8578	1.60 <sup>3</sup>	0.00	8.00	3.0	0.5
MS650-BA	M7622-AA	3.5	0.00	17.5	-	-

<sup>1</sup>Also include -12 Vdc @ 0.25 A, 3 W.

<sup>3</sup>Value is for the unpopulated module only.

<sup>4</sup>Includes the power requirement of the H3602.

**Table 3–1 (Cont.): Power Requirements**

Option	Module	Current (Amps) Max		Power Max	Bus Loads	
		+5 V	+12 V	Watts	AC	DC
MS650-BB	M7622-BB	3.1	0.00	15.5	–	–
RF31E-AA/AF	–	1.2	2.21	32.52	N/A	N/A
RF31F-AA/AF	–	1.2	2.21	32.52	N/A	N/A
RF71E-AA/AF	–	1.25	1.64	25.93	N/A	N/A
RF72E-AA/AF	–	1.20	1.75	27.00	N/A	N/A
RZ56E-AA/AF	–	1.36	2.1	32.0	N/A	N/A
RZ57E-AA/AF	–	1.36	2.1	32.0	N/A	N/A
TF85E-JA/JF	–	1.50	2.40	36.30	N/A	N/A
TK50E-AA	–	1.50	2.40	36.30	N/A	N/A
TK70E-AA	–	1.50	2.40	36.30	N/A	N/A
TLZ04-JA/JF	–	1.5	2.4	36.3	N/A	N/A
TQK50-SA/SF	M7546	2.9	0.00	14.5	2.8	0.5
TQK70-SA/SF	M7559	3.50	0.00	17.50	4.3	0.5
TSV05-SA	M7530	6.50	0.00	32.50	1.5	1.0
VCB02-A	M7615	4.6	0.10	24.2	3.5	1.0
VCB02-B	M7168-00 M7169	8.85	0.47	49.89	3.5	1.0
VCB02-C	(2) M7168-00 M7169	12.0	0.47	65.64	3.5	1.0

# Index

---

## A

---

Asynchronous serial controllers  
description of, 2–38

## B

---

BA430 enclosure, 1–1  
Base system  
description of, 1–1  
Break Enable/Disable switch  
description of enable setting, 1–4

## C

---

Communications options  
supported, list of, 2–38  
Console commands  
qualifier and argument  
conventions in Console  
I/O mode, 1–6  
Console I/O mode  
and examples of SET and SHOW  
commands, 1–9  
console commands, 1–6  
description of, 1–4  
Console program, 1–3  
and power-up mode, 1–4  
entering Console I/O mode, 1–4  
Control and status register (CSR)  
assigning, 3–1  
description of, 2–2  
Controllers, mass storage  
supported in KA660 systems, list  
of, 2–3  
CSR  
*See* Control and status register

## D

---

Device abbreviations, 1–13  
DHU11 mode  
and CXA16 support, 2–39  
and CXB16 support, 2–42  
DHV11 mode  
and CXA16 support, 2–39  
and CXB16 support, 2–42  
Digital Storage Systems Interconnect  
*See* DSSI  
DSSI  
description of, 1–14

## E

---

Expanding your system, 3–1

## F

---

Firmware  
system control of, 1–3

## I

---

Integrated storage element (ISE)  
and support on DSSI bus, 1–14  
RF-series, description of, 2–14,  
2–15, 2–17, 2–18  
Interrupt vector  
description of, 2–2

## K

---

KA660-AA/-BA module  
system names for, 1–15



## **M**

---

Mass storage controllers

*See* Controllers

Modules

KA660-AA/-BA CPU, location of,  
1-1

MS650-Bx memory, location of,  
1-1

MS650-Bx module

and maximum supported number,  
1-1

## **N**

---

Network controllers

description of, 2-38

## **P**

---

Power supply

minimum load, 3-6

Power-up self-tests

description of, 1-3

## **R**

---

Real-time options

supported, list of, 2-56

## **S**

---

Self-tests

*See* Power-up self-tests

SET BOOT command, 1-12

SET command

description of, 1-9

SET LANGUAGE command, 1-11

SHOW command

description of, 1-9

SHOW DEVICE display, 1-11

SHOW ETHERNET display, 1-11

SHOW LANGUAGE display, 1-11

SHOW QBUS display, 1-9

Storage devices

supported in KA660 systems, list  
of, 2-3

Synchronous serial controllers

description of, 2-38

## **V**

---

VMB

description of, 1-3